

1. Product Features

- It's a lithium battery sensing controller, applicable to ternary-material lithium, lithium iron phosphate, lithium cobalt oxide and other types of lithium batteries.
- Boasts a load triple-stage sensing design, with an operating duration adjustable from 0 to 15 hours and a power setttable from 0 to 100% accordingly for human-detected and human-undetected situations.
- Features a pyroelectricity human body infrared sensing function(PIR Function).
- Its sensing time delay is setttable from 0 to 250 s.
- Features a lithium battery auto-activation function.
- Boasts an extremely low sleep-mode power consumption.
- Flexible charging methods are available, with direct charging and PWM charging freely switchable.
- Employs a lithium battery low-temperature charging protection function. When the ambient temperature falls below the freezing point, charging will be halted to protect the battery.
- Features an intelligent power mode which can extend the battery life to its top limit by adjusting the load power automatically according to the remaining battery capacity.
- Digital and high-precision constant current control boasting an efficiency of up to 96%.
- Features a system status log function, able to record a maximum of 7 days of system status, comprehensively and effectively monitoring the system's conditions.
- Operated through a wireless remote control.
- An overheat protection function enables the device to scale down the load or shut off the load completely when its temperature exceeds a certain point.
- A range of protection measures such as battery reverse-connection protection, LED short-circuit and open-circuit protection, etc., put the system under comprehensive and constant guard.

2. Exterior and Wiring

1. Model name composition

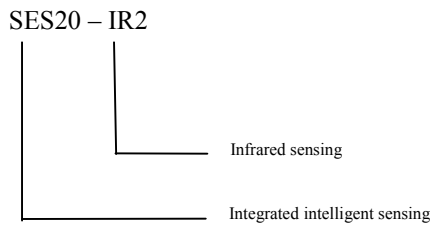

2. Exterior

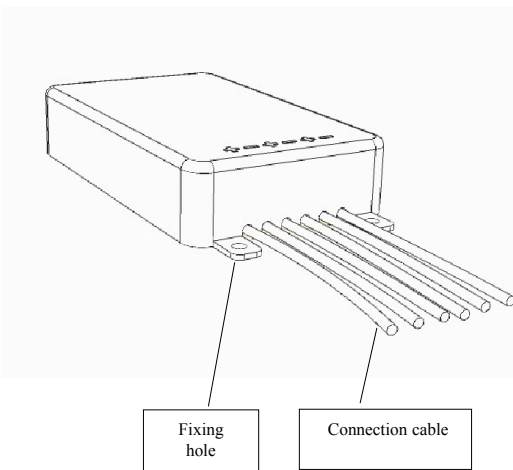

3. Wiring diagram

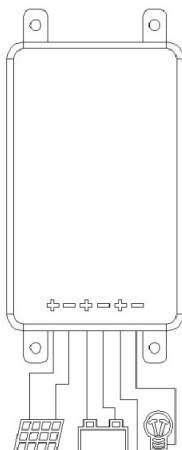

4. Wiring sequence: connect first the load, second the battery, and finally the solar panel (for first-time activation, the solar panel voltage needs to be higher than 11.5 V).
5. Sensing range (max. value):

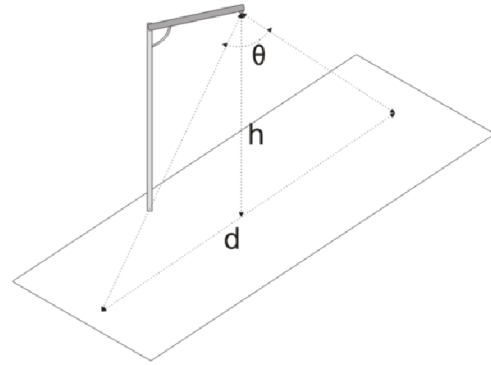

Controller model	θ (angle)	h (height)	d (width)
SES20-IR2 (infrared)	60°	6m	7m

3. LED Load Connection

1. With a built-in boost type constant current source, SES20-IR2 boasts a maximum output voltage of 60V, able to power up to 18 LED light bulbs.
2. This controller is of a boost type. When LED load is connected, be sure to connect a right number of LED lights in series.

The number of connected LED lights is recommended as follows:

System voltage	Recommended minimum No. of serially connected LEDs (n)	Load output voltage V_{out}
12V	$n \geq 5$	$V_{out} \geq 15V$

3. In practical use, make sure you correctly connect the LED lights before switching on the load. **Warning: if a wrong number of LED lights are connected in series, the LED load or the controller may get damaged. Always bear this in mind!**

4. State Indicators

LED indicator status	Meaning
Steady on	Controller in normal operation
Single flashing	Controller in sleep mode
Slow flashing	Charging in process
Quick flashing	System in abnormality
Off	Battery not activated or not connected

5. Load Working Modes

Controlled by the SES20-IR2 controller, the load is operating in a 3-stage sensing mode. The operating duration and power of each stage can be freely adjusted, with different combinations bringing about different control modes.

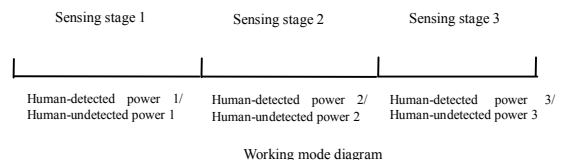

- A. **Normal working mode:** operates according to time and power settings in sequence.
- B. **Delay sensing mode:** e.g., if you set sensing stage 1 to 4 hours and both human-detected power 1 human-undetected power 1 to 100%, the system will delay entering into the 2nd sensing stage by 4 hours.
- C. **All-night sensing mode:** e.g., if you set sensing stage 1 to 15 hours, human-detected power 1 to 100% and human-undetected power 1 to 30%, the system will enter into the all-night sensing mode. When a human is detected, the load will light up at 100%; when he/ she leaves, the load will dim down to 30% after a delay of 10 s.
- D. **Test mode:** in daily use, the controller works in the light control + time control mode, but when test is needed during installation, you can use the remote control to switch on the load, and then the LED load will change its power according to the remote control settings. The test mode lasts for 1 minute, and after that, the system will automatically restore the normal working mode.

Adjustment item	Value	Default
Sensing stage 1	0 to 15 hours	4

Human-detected power 1	0 to 100%	100%
Human-undetected power 1	0 to 100%	100%
Sensing stage 2	0 to 15 hours	4
Human-detected power 2	0 to 100%	100%
Human-undetected power 2	0 to 100%	30%
Sensing stage 3	0 to 15 hours	15
Human-detected power 3	0 to 100%	50%
Human-undetected power 3	0 to 100%	0%
Sensing delay	0 to 250 s	10

6. Intelligent LED Power Control

When the controller's "intelligent power" mode is activated by the user, the LED load's power can be automatically adjusted according to the battery capacity. While the operating duration and load power set by the user are still valid, the system will choose the smaller one from between the automatically adjusted power and the power set by the user as the load output power.

For example: when the remaining battery capacity is 50% and the load power calculated in the intelligent power mode is 60%, and if the load power set by the user is 100%, then the final load power is 60%; however, if the load power set by the user is 20% instead, the final load power will also become 20% accordingly.

The typical curve of intelligent power is shown below:

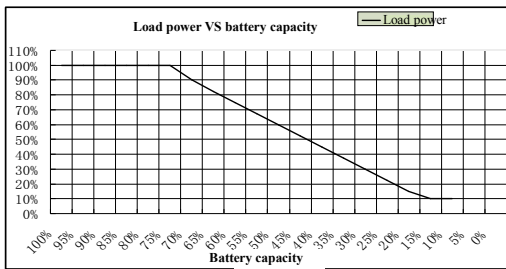

7. Parameter Access and Modification

The SES20-IR2 controller can be used to set parameters including load operating duration, load operating power, light control delay and charging voltage, etc. When finishing settings through the remote control, aim it at the controller and press the "send" key to save the settings. Besides, current parameter settings in the controller can also be accessed to make sure the settings are correct.

8. Low Power Consumption Sleep mode

When an installed conventional controller needs to be transported a long distance, it will turn on the light on the way, which not only results in energy waste, but also increases transportation risks. To address this problem, a conventional controller needs an additional mechanical switch to shut off the main power supply. However, a sleep-mode function can effectively solve this problem in a better way. After receiving a command from the remote control, the controller will immediately enter into a "sleep mode"; when exposed in sunlight again, the controller will automatically exit sleep mode and switch to normal working mode.

9. Charging Control

1. charging methods are available—direct charging and PWM charging, from which the user can choose based on the characteristics of the battery adopted.

A. Direct charging:

Direct charging is a conventional on/ off charging method. When the battery voltage reaches the overcharge point, the charging circuit will be disconnected and thus halt charging; when the battery voltage falls to the overcharge recovery point, charging will be resumed. When malfunctions easily occur due to the lithium battery protection board's sensitivity to PWM pulse charging, this charging method can be used.

B. PWM charging:

In PWM charging, when the battery reaches the full-charge point, the controller will automatically adjust the charging duty ratio and begin to charge the battery in a constant voltage mode, and from then on the charging becomes pulse charging with discontinuous current. Pulse charging can make the battery safer and charging faster, and during charging interruptions, intermediate substances generated by chemical reactions in the battery have enough time to recombine chemically and then get absorbed. This can enable the battery to collect more electricity and raise the battery's receptance to charging current.

2. Freezing point charging protection

Temperature has a substantial bearing on lithium batteries' performance. When the ambient temperature falls below 0 °C, the lithium battery' properties will change significantly and its capacity will shrink rapidly, making charging no longer feasible. With the freezing point charging protection function enabled, when an ambient temperature below 0 °C is detected, the controller will stop charging the battery so as to avoid damaging the battery.

10. Dimensions and Installation Diagram

1. Controller dimensions

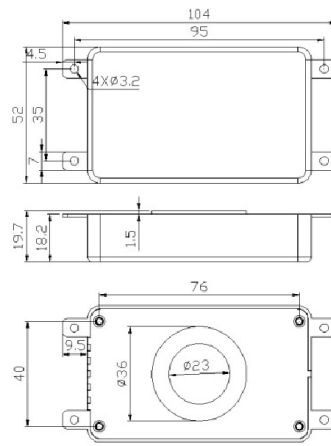

SES20-IR2's dimensions are as follows:
External dimensions: 104×52×19.7 (mm)
Installation dimensions: 95×35 (mm)
Installation hole diameter: 3.2 (mm)

2. Installation diagrams

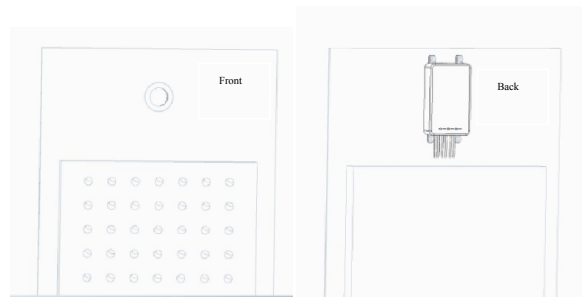

11. System Status Log

The SES20-IR2 controller can record the operating status of the whole system, including operating days, over-dischargings, full-chargings, etc. And besides, it can also keep a record of battery voltage changes in a week, enabling the user to have a clear understanding of the system and conduct better analysis on it. The user needs to use the remote control to read the system's operating status, and when the reading is successfully done, the parameters will be recorded in the remote control.

12. Typical Efficiency Curve

12 V system

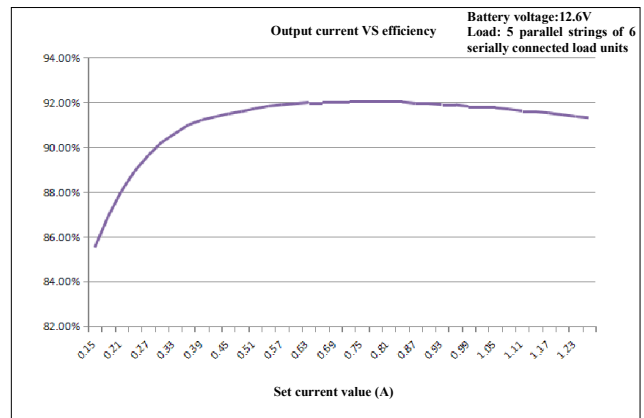

13. Parameter Details

Parameter	Value	Adjustable or not	Default
Model	SES20-IR2		
System voltage	12V		
Output power	20W/ 12V		
Output current	0.15A to 1.67A	√	330mA
No-load loss	13mA/ 12V		
Sleep mode power consumption	0.21mA/ 12V		
Charging current	5A		
Solar energy input voltage	< 30V		

Typical constant current source efficiency	90% to 93%		
Over-voltage protection	Overcharge voltage + 2 V		16.6V
Charging voltage limit	Overcharge voltage + 1V		15.6V
Overcharge voltage	9.0 V to 17.0 V	√	14.6V
Overcharge recovery voltage	9.0 V to 17.0 V	√	13.6V
Over-discharge voltage	8.0 V to 17.0 V	√	10.0V
Over-discharge recovery voltage	9.0 V to 17.0 V	√	12.0V
Current accuracy	±3% (load current > 300 mA)		
Load output voltage	< 60V		
Over-temperature protection	Ambient temperature: 80°C (load downrating power)		
Over-temperature protection	Inside temperature: 120 °C (load off)		
Light control voltage	5V to 11V	√	5V
Light control delay	0 min to 50min	√	0min
Sensing delay	0 S to 250 S	√	10S
Operating temperature	-35°C to +65 °C;		
Sensing range	6 m vertically, 7 m horizontally		
Protection degree	IP68		
Weight (g)	120g		
Controller dimensions (mm)	104×52×19.7		

Note: parameter settings shall comply with the following rule, i.e. overcharge voltage > overcharge recovery voltage > over-discharge recovery voltage > over-discharge voltage.

14. Frequently Met Abnormalities and Solutions

Symptoms	Causes and solutions
Indicator off	Check whether controller wiring is sound and reliable or whether the controller enters into sleep mode.
Indicator flashing quickly	Check whether the battery is over discharged, or whether the load is open-circuited or short-circuited.
No charging with sunlight present	Check whether the solar panel is correctly connected and whether it's blocked.
The load current doesn't reach the set value.	Check whether the current value exceeds the max. current allowed by the controller.

Note: for detailed parameter and status information, refer to the CU-ALL Instruction Manual.

The contents of this manual are subject to change without prior notice.