



QUICK206D

High-Power Intelligent Lead Free Soldering Station

Operation and Maintenance Manual

Thank you for purchasing an Intelligent Lead Free Soldering Station. It is designed for lead free soldering. Please read this manual before operating the unit. Store this manual in a safe, easily accessible place for future reference.

Table of Contents

Precautions.....	1
Name of Parts.....	2
Setting up & Operating station.....	2
Parameters.....	5
Sleeping.....	10
Select the Correct Tip for a Soldering Station.....	10
Calibrating the Iron Temperature.....	10
Tip Care and Use.....	11
Maintenance.....	11
Error Messages.....	13
Trouble Shooting Guide.....	14
Checking for Breakage of the Heating Element and Cord Assembly.....	14
Replace the Fuse.....	14
Specification.....	14
Tips.....	15

Precautions

In this instruction manual, “Warning”, “Caution” and “Note” are defined as followings.

⚠ WARNING

⚠WARNING: Misuse may potentially cause death of, or serious injury to the user.

⚠CAUTION: Misuse may potentially cause injury to the user or physical damage to the objects involved. For your own safety, be sure to comply with these precautions.

NOTE: A NOTE indicates a procedure or point that is important to the process being described.

⚠ CAUTION

When the power is on, the tip temperature is very high. Since mishandling may lead to burns or fire, be sure to comply with the following precautions.

- Please don't abuse of the equipment, use the unit only as the described manners.
- Don't touch the metallic parts near the soldering tip.
- Don't use the unit near flammable items.
- Advise other people in the work area that the unit can reach a very high temperature and should be considered potentially dangerous.
- Turn the power off while taking breaks and when finished using the unit.
- Before replacing parts or storing the unit, turn the power off and wait the unit cooling to the room temperature.

7.TIPS

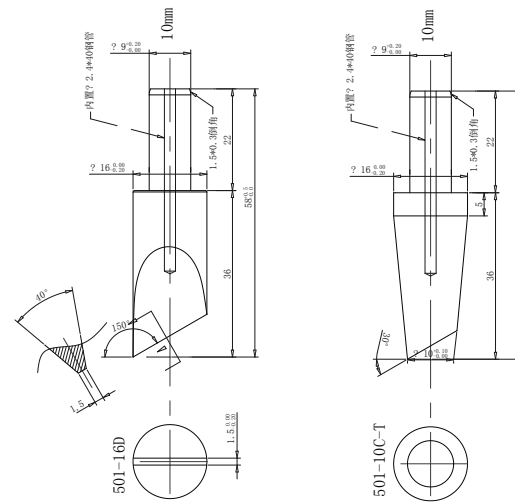
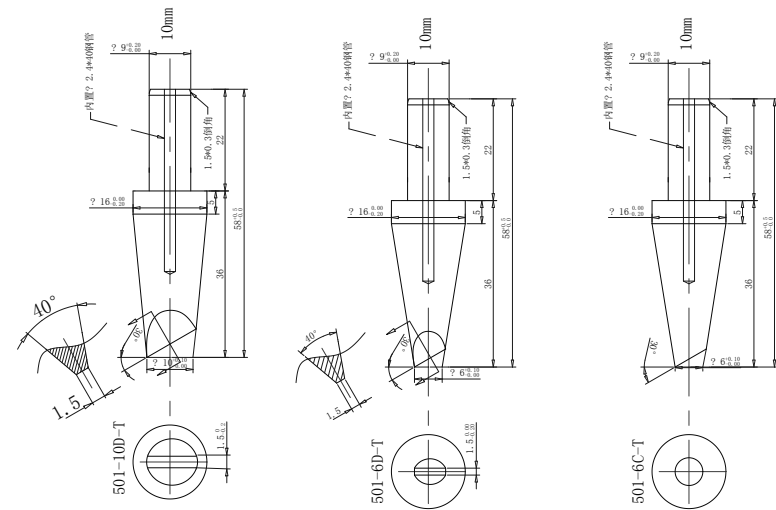

3. When not in use

Never leave the soldering iron sitting at high temperature for long periods of time, as the tip's solder plating will be covered with oxide, which can greatly reduce the tip's heat conductivity.

4. After use

Wipe the tip and coat it with fresh solder. This helps to prevent tip oxidation.

6.3 Maintenance

1. Inspect and Clean the Tip

⚠Caution: Never file the tip to remove oxide.

- (1) Set the temperature to 250°C.
- (2) When the temperature stabilizes, clean the tip with the cleaning sponge and check the condition of the tip.
- (3) If there is black oxide on the solder-plated portion of the tip, apply new solder (containing flux) and wipe the tip on the cleaning sponge. Repeat until the oxide is completely removed. Coat with new solder. The solder protects the tip from oxidation and prolongs the life of the tip.
- (4) If the tip is deformed or heavily eroded, replace it with a new one.

2. Why a “de-tinned” tip fails to work?

A de-tinned tip is one which cannot wet with solder. This exposes the plating to oxidation and degrades the heat transfer efficiency of the tip. It is caused by:

- (1) Failure to keep the tip covered with fresh solder while not in use.
- (2) High tip temperatures.

To prevent damage to the unit and ensure a safe working environment, be sure to comply with the following precautions.

- Appliance shall only be used with rated voltage and frequency. (Refer to the trademark back of equipment.)
- Don't use or stop the use if the appliance is damaged, especially the supply cord.
- This machine is equipped with a 3-wires grounding plug and must be plugged into a 3-terminal grounded socket. Do not modify plug or use an ungrounded power socket. If an extension cord is necessary, use only a 3-wire extension cord that provides grounding.
- Do not use the unit for applications other than soldering.
- Do not rap the soldering iron against the work bench to shake off residual solder, or otherwise subject the iron to severe shocks.
- Do not modify the unit.
- Use only genuine replacement parts.
- Do not wet the unit or use and disconnect the unit when your hands are wet and without to force the supply cord.
- The soldering process will produce smoke, so make sure the area is well ventilated.
- While using the unit, don't do anything which may cause bodily harm or physical damage.
- Children don't recognize the risks of electrical appliances. Therefore use or keep the appliance only under supervision of adults and out of the reach from children.

I . Summary

This unit is an intelligent lead free soldering station with LCD double temperature display. The temperature calibration adopts digital manual, and the operation is convenient. The temperature induction is very exact and sensitive, the speed of heating and recovery of temperature is very fast, and so it is the one of the most perfect tools for lead free soldering.

II . Feature

1. High frequency current heating and rapid recovery of the temperature.
2. Replace tips conveniently and it can get the temperature of tip exactly.
3. LCD, double temperature display.
4. Digitally calibrate, operate conveniently.
5. It can set the up and down limited temperature, and alarming when temperature is over range.
6. It can set the time of auto sleeping and turning off.
7. Especially be suitable for lead free soldering.
8. ESD safe by design.

III. Specifications

Power consumption	320W
Range of temperature	50°C~550°C Decided by working mode
Highest Ambient Temperature	40°C
Temperature Stability	±2°C/Without air flow and no load
Soldering station size	245 (L) *100 (W) *200(H)mm
Tip to Ground Potential	<2mV
Heating Element	Electromagnetic heater
Handle Power Cord	1.8m (The length can be ordered)
Weight	2.8kg

VI. Tip Care and Maintenance

6.1 Select a Correct Tip

1. Select a tip that maximizes contact area between the tip and solder joint. Maximizing contact area gives the most efficient heat transfer, allowing operators to produce high quality solder joints quickly.
2. Select a tip that allows good access to the solder joint. Shorter tip lengths allow more precise control. Longer or angled may be needed for soldering densely populated boards.

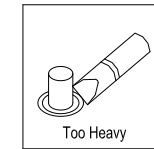
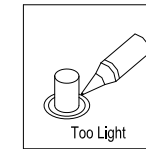
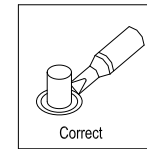

6.2 Tip Care and Use

1. Tip temperature

High soldering temperature can degrade the tip. Use the lowest possible soldering temperature. The excellent thermal recovery characteristics ensure efficient and effective soldering event at low temperatures. This also protects the sensitive components from thermal damage.

2. Cleaning

Clean the tip regularly with a cleaning sponge, as oxides and carbides from the solder and flux can form impurities on the tip. These impurities can result in defective joints or reduce the tip's heat conductivity.

When using the soldering iron continuously, be sure to loosen the tip and remove all oxides least once a week.

This helps prevent reduction of the tip temperature.

5.5. Off time setting

If the system isn't resumed during the sleeping time, the power supply will be shut off automatically, and the soldering part will stop working. Turn on the power switch to resume working.

- 1) The process of setting "off time" is after the process of setting "sleep time". At the "off time" status, the display shows  and then press "△" or "▽" key to change the off time.
- 2) The range of sleeping time is from 0 minute to 250 minutes.

Note: The off time should be longer than the sleep time, otherwise, the soldering station part will be turned off immediately after it comes into sleep state.

5.6 Sleeping temperature setting

- 1) In the process of "sleeping temperature" setting, the display shows "sleep" and "set temp", and then press "△" or "▽" key to change the sleeping temperature.
- 2) The range of sleeping temperature is from 50°C to 250°C.

** The tip temperature is measured by 191/192 thermometer.*

** Specifications and design subject above will be changed without notice.*

4. Setting & Operating the Soldering Station

⚠CAUTION:

Before operation, please check whether the voltage accords with the rated voltage on the unit's nameplate.

4.1 Iron Holder and Sponge

⚠CAUTION:

- The sponge is compressed. It will swell when moistened with water. Before using the unit, moisten the sponge with the water and squeeze it dry. Failure to do so may result in damage to the soldering tip.
- If the sponge becomes dry during working, add appropriate water.

1. Dampen the small cleaning sponge with water and then squeeze it dry.
2. Place it in groove of the iron holder base.
3. Add a little water to iron holder. The small sponge will absorb water to keep the large sponge around it wet at all times.
4. Dampen the large cleaning sponge and place it on the iron holder base.

4.2 Connection

⚠CAUTION:

Be sure to turn off the power switch before connecting or disconnecting the soldering iron. Failure to do so may damage the soldering station.

1. Connect the connector of the handle cord to the socket behind the unit. Take notice of inserting position about connector.
2. Place the soldering iron at the iron holder.
3. Insert the power plug into grounded power socket.
4. Turn on the power switch.

4.3 Setting the Temperature

⚠ CAUTION:

Make sure the temperature of the unit can be adjusted (password is correct or the password is initial 000). When setting temperature, the heating element is on. Operation as following steps:

Temperature rising:

Press “▲” button directly. If so, the setting temperature will raise 1°C and the display window will display the set temperature. When loosen the “▲” button, the display window will delay to display the set temperature about 2seconds. If within 2seconds, press the “▲” button again, the setting temperature will raise 1°C again. If press the “▲” button and not loose at least 1second, the setting temperature will rise rapidly. Till the needed temperature reaches, then loose the “▲” button.

Temperature dropping:

Press “▼” button directly. If so, the setting temperature will drop 1°C and the display window will display the set temperature. When loose the “▼” button, the display window will delay to display the set temperature about 2seconds. If 2seconds later, press the “▼” button again, the setting temperature will drop 1°C again. If press the “▼” button and not loose at least 1second, the setting temperature will drop rapidly. Till the needed temperature reaches, then loose the “▼” button.

4.4 Calibrating the Temperature

The soldering iron should be recalibrated after changing the iron, or replacing the heating element or tip. The unit adopts digital calibration mode and the revision value is inputted by pressing button, make the adjustment easily.

5.4 Setting Sleep Time

The station has an auto-sleep function. When not operating the station during a certain period of time (the setting sleep time), the power supply will be cut off and the station will come into the sleep state.

- 1) Select the needing mode and then press “*” key to the process of “sleep time” setting. The display shows  and then press “△” or “▽” key to change the sleeping time. The range of sleeping time is from 0 to 250 minutes.
- 2) After finishing setting the sleeping time, press “*” key to the process of off time setting.
- 3) To resume soldering, there are several ways as follows:
 - * Turn the power switch off and then turn on.
 - * Press any key of the soldering part.
 - * Take up the iron- handle.

Note: The soldering iron must be placed at the soldering iron station. And only in this state, the soldering station can sleep automatically when up to the setting time.

- pressing “▲” or “▼” button will change displayed value as shown below:

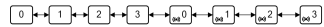

Work mode form

Working Mode	Tip Type	TIP type	Temperature	Alarm Function
0	80°C~480°C	Super large tip	no	((O))is alarm mark
1		Common tip		
2	50°C~550°C	Super large tip		
3		Common tip		
((O)) 0	80°C~480°C	Super large tip	yes	
((O)) 1		Common tip		
((O)) 2	50°C~550°C	Super large tip		
((O)) 3		Common tip		

! WARNING:

The heater and soldering tips will be seriously oxidized or damaged when working with high temperature. So please choose the working mode carefully and try to operate with lower temperature if possible.

5.3 Up and Down Limit of Temperature

- In the up temp setting state, the display shows “050” and press “▲” or “▼” key to change the temperature. Once difference in temperature between the real temperature (Real Temp) and the setting temperature (Set Temp) is bigger than the Up Temp, the soldering station part will alarm when in the alarming mode.
- The range of the “Up Temp” setting is from 0°C to 99°C.
- In the down temp setting state, the display shows “050” and press “▲” or “▼” key to change the temperature. Once difference in temperature between the real temperature (Real Temp) and the setting temperature (Set Temp) is bigger than

Method of recalibrating temperature: use the thermometer to calibrate it and it is precise comparatively. Calibrate by using thermometer:

- Set the unit’s temperature to a certain value.
- When the temperature stabilizes, measure the tip’s temperature with thermometer and write down the reading.
- Press “*” button not loosen and press the “▲” and “▼” button simultaneously, the soldering station enters into calibrating temperature mode and LCD display “Cal Temp”.

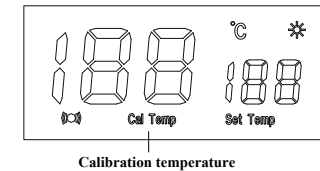

- Press the “▲” and “▼” button to select the value. After selecting, press “*” button.
- If the temperature still has departure, you can repeat calibration in accordance with the above steps.
 - Suggest measure the tip’s temperature with 191/192 thermometer.
 - If the soldering station is locked by password, it will not be able to calibrate the tip temperature and you must input the right password.

Example: Input the calibration temperature 350 °C (tested by the thermometer), when the display temperature is 400 °C.

- Press “*” button not to loose and press the “▲” and “▼” buttons simultaneously, the soldering station enters into calibrating temperature mode.
- Press “▼” button to change displayed value ,until show as 350 °C. press “*” button.

Note: If you turn off the power switch during the temperature setting, the setting value will not be stored in the memory. If the temperature value is outside of allowable range, the system may not store this temperature value.

V. Setting Working Parameters

The station has the following working parameters. If you want to set parameters, you must input right password. Setting parameters as follows:

5.1 Setting Password

The initial password in station's memory is "000". The setting temperature is admitted in this status. If need to restrict the setting temperature, the password must be changed and turn off the unit, then turn on.

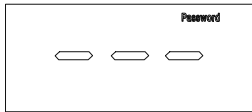

- **Enter into setting password**

1. Turn off the power switch, Press and hold the “▲” and “▼” buttons simultaneously, then turn on the power switch.
2. Show “---” ,press “*” key, Show “000”
3. Press “*” key, show  , the unit is in parameter setting mode.

- **Input previous password**

Press the“*”button, the LCD shows “000” and Password” typeface, (000 is initial password) Press “*” key.



- **The input password is error**

If the station enters into normal work state after display window shows the current setting temperature for two seconds, this indicates the input password is error, and the temperature setting can't be done.

- **The input password is correct**

If the display window shows  , this indicates the password of input is correct. Press “*” key, the unit comes into the normal work state, and the temperature setting and parameter setting will be admitted.

- **Input new password**

When display window is showing  , press the “*” button and “▲” button, and shows  , it indicates the station comes into inputting new password state. Press “▲” or “▼” button to change the displaying value. See “Input calibration temperature”.

- **Repeat the new password**

When three digits are selected, press “*” button, the display window shows  again. Now input the new password once again.

Repeat the same steps as the inputting new password.

If the latest two passwords are the same, pressing “*” button will modify the password successfully. The new password is stored into the internal memory.

If the latest two passwords are not the same, pressing “*” button, and the display window shows  , it needs to rewrite new password. (See the last 8~9 step). The changing of password is successful until the latest two passwords are the same.

Note: The word of password is 0 to 9, ten figures. If not, the input password is invalid.

5.2 Setting Working Mode

1. When the display window shows  , press “▲” and “*” buttons simultaneously, This indicates the unit comes into working mode setting state