

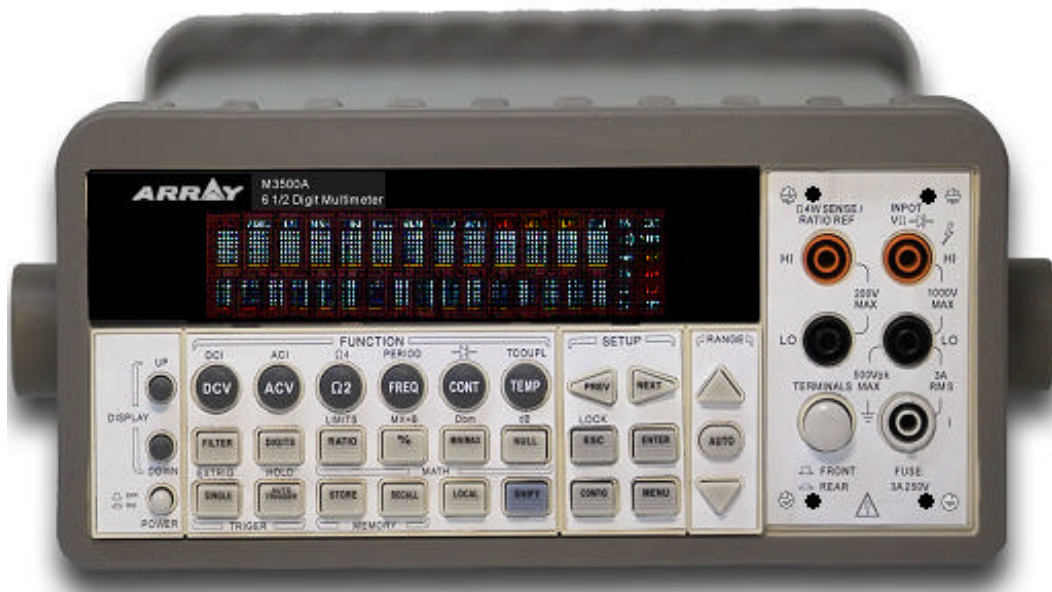

M3500A

6½ Digit Digital Multimeter



User's Manual

M3500A DMM

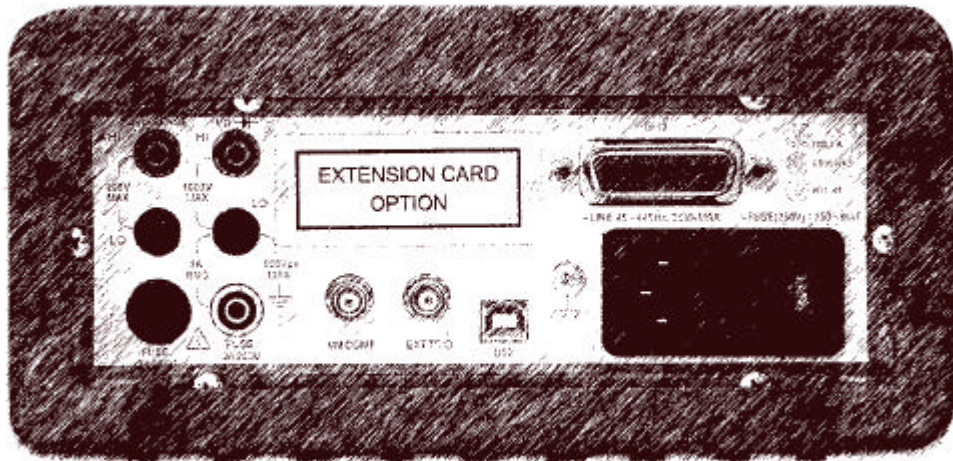
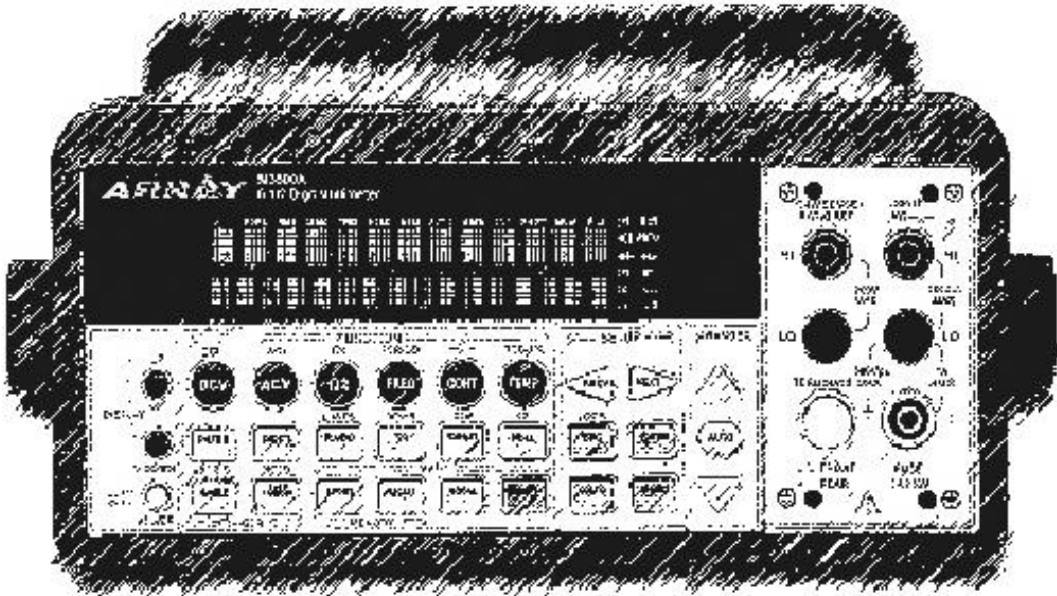

User's Manual

Table of Contents

1 GENERAL INFORMATION.....7

1.1	FEATURE OVERVIEW.....	7
1.2	WARRANTY INFORMATION.....	8
1.3	PRECAUTION OF OPERATION.....	9
1.4	UPKEEP OF M3500A	10
1.5	SAFETY INFORMATION.....	10
1.6	SYMBOLS AND TERMS	11
1.7	INSPECTION.....	12
1.8	OPTIONS AND ACCESSORIES.....	12

2 OVERVIEW.....14

2.1	SETTING UP YOUR M3500A DIGITAL MULTIMETER	14
2.1.1	<i>To adjust the handle</i>	<i>14</i>
2.1.2	<i>To connect the power.....</i>	<i>17</i>
2.1.2.1	<i>To convert the voltage.....</i>	<i>17</i>
2.1.2.2	<i>To change the fuse.....</i>	<i>20</i>
2.1.3	<i>Factory Default When Power-ON.....</i>	<i>24</i>
2.2	FEATURES.....	26
2.3	M3500A FUNCTION INTRODUCTION.....	26
2.3.1	<i>The Front Panel.....</i>	<i>26</i>
2.3.2	<i>The Display.....</i>	<i>30</i>
2.3.2.1	<i>Annunciators at Upper Side.....</i>	<i>30</i>
2.3.2.2	<i>Annunciators at Right Side.....</i>	<i>31</i>
2.3.3	<i>The Rear Panel.....</i>	<i>31</i>

3 BASIC MEASUREMENT FUNCTION.....33

3.1	VOLTAGE MEASUREMENTS (DC & AC)	33
3.2	CURRENT MEASUREMENTS (DC & AC)	35
3.3	RESISTANCE MEASUREMENTS (2 & 4-WIRE)	37
3.4	FREQUENCY & PERIOD MEASUREMENTS	39
3.5	CONTINUITY MEASUREMENTS	40
3.6	DIODE MEASUREMENTS	41
3.7	TEMPERATURE MEASUREMENTS	42
3.7.1	<i>Thermocouple Measurements</i>	43
3.7.2	<i>RTD Measurements</i>	43
3.7.2.1	2-Wire RTD Measurements	44
3.7.2.2	3-Wire RTD Measurements	45
3.7.2.3	4-Wire RTD Measurements	47

4 FRONT PANEL OPERATIONS50

4.1	MEASUREMENT CONFIGURATION	50
4.1.1	<i>Set ADC (Auto Zero & Auto Gain)</i>	50
4.1.2	<i>Filter</i>	53
4.1.2.1	AC Filter	53
4.1.2.2	Digital Filter	54
4.1.3	<i>Resolution Setting (Digits)</i>	56
4.1.4	<i>DC Input Resistance</i>	58
4.1.5	<i>Threshold Resistance (Continuity)</i>	59
4.1.6	<i>Range (Manual and Auto)</i>	60
4.1.7	<i>Rate (Integration Time)</i>	62
4.1.8	<i>Sensor Selection for Temperature Measurements</i>	63
4.1.9	<i>Remote Interface Selection</i>	67
4.1.10	<i>Input Terminal Switch</i>	68
4.2	TRIGGER OPERATIONS	68
4.2.1	<i>Trigger Mode</i>	69
4.2.2	<i>Trigger Source</i>	71
4.2.3	<i>Trigger Setting</i>	72
4.3	MATH OPERATIONS	77
4.3.1	<i>Ratio</i>	77
4.3.2	<i>% (Percent)</i>	79

4.3.3	<i>Min/Max</i>	80
4.3.4	<i>Null</i>	82
4.3.5	<i>Limits Test</i>	83
4.3.6	<i>MX+B</i>	85
4.3.7	<i>dB/dBm</i>	87
4.4	OTHER SYSTEM RELATED OPERATIONS.....	91
4.4.1	<i>Display</i>	91
4.4.2	<i>Beeper</i>	93
4.4.3	<i>Reading Memory (Store & Recall)</i>	94
4.4.4	<i>Sensitivity Band (Hold)</i>	96
4.4.5	<i>Scanning (Scan)</i>	97
4.4.6	<i>Stepping (Step)</i>	100
4.4.7	<i>Initial Mode</i>	101
4.4.8	<i>Language</i>	102
4.4.9	<i>Error Condition</i>	103
4.4.10	<i>Firmware Revision</i>	104
4.4.11	<i>Calibration</i>	104

5 REMOTE INTERFACE OPERATIONS.....106

5.1	SETTING UP FOR REMOTE INTERFACE.....	106
5.2	REMOTE INTERFACE COMMANDS.....	107

6 ERROR MESSAGES.....119

6.1	ERROR TYPE.....	119
6.1.1	<i>Execution Errors</i>	119

APPENDIX.....124

A.	SPECIFICATION LIST.....	124
B.	REMOTE INTERFACE REFERENCE.....	127
B.1	<i>An Introduction to the SCPI Language</i>	127
B.2	<i>Output Data Formats</i>	131
B.3	<i>The MEASure? Command</i>	132

<i>B.4 The CONFigure Command.....</i>	<i>134</i>
<i>B.5 The Measurement configuration command.....</i>	<i>136</i>
<i>B.6 The Math Operation Command.....</i>	<i>141</i>
<i>B.7 The Triggering Commands.....</i>	<i>144</i>
<i>B.8 The System-Related Commands.....</i>	<i>146</i>
<i>B.9 Status Reporting Commands.....</i>	<i>147</i>
<i>B.10 SCPI Compliance Information.....</i>	<i>149</i>
<i>B.11 IEEE-488 Compliance Information.....</i>	<i>151</i>
C. ABOUT APPLICATION PROGRAMS	153

1 General Information

This section contains general information about ARRAY M3500A Multimeter. The information is shown below:

- Feature Overview
- Warranty Information
- Safety Information
- Symbols and Terms
- Specifications
- Inspection
- Options and Accessories

If you have any questions after reading this information, please contact your local service representative.

1.1 Feature Overview

M3500A is a 6½ digit digital multimeter. It has 0.0015% 24-hour basic DC voltage accuracy at 10V range and 0.002% 24-hour basic resistance accuracy at 10kΩ range. At 6½ digit, the multimeter delivers 50 triggered RDGS/sec via remote interface. At the fast 4½ digit, it reads over 2000 RDGS/sec into its internal buffer. M3500A provides wide measurement ranges:

? **Note: The 24-hour measurement is subject to calibration accuracy.**

- DC voltage: 0.1V, 1V, 10V, 100V & 1000V.
- AC voltage: 0.1V, 1V, 10V, 100V & 750V.
- DC current: 10mA, 100mA, 1A & 3A.
- AC current: 1A & 3A.
- 2 & 4-wire resistance: 100Ω, 1KΩ, 10KΩ, 100KΩ, 1MΩ, 10MΩ &

100MO.

- Frequency: From 3Hz to 300kHz.
- Period measurement.
- Diode measurement.
- Continuity measurement for resistance.
- Thermocouple temperature & RTD measurements.

Some additional capabilities of M3500A include:

- Full math functions – dB, dBm, MX+B, ratio, %, Max/Min, null & limits.
- Optional multipoint scanner card – For internal scanning, options include M3500–opt01, a 10-channel, general-purpose card.
- USB and GPIB (Optional) remote control interfaces.
- Through Microsoft Office Word & Excel for remotely storing and recalling the measured values.
- Through M3500 AP software for simulating the real operation on PC.

1.2 Warranty Information

1. **Warranty:** ARRAY guarantees that this product meets its published specifications at the time of shipment from the factory. Under proper installation it should work as expected.
2. **Warranty Period:** This equipment is warranted against defects in material and manufacturing for a period of one year from the date of shipment. During the warranty period, ARRAY is responsible for necessary repairs as long as the product can be proved to be defective.
For warranty service or repair this product must be returned to a service facility designated by ARRAY. Please contact your local service representative.
3. **Excluded Items:** This warranty does not include consumptive parts such as fuses, buttons and relays. Neither does this warranty cover defects caused by improper installation, improper or insufficient maintenance, unauthorized modification, improper operation,

ignorance of environmental specifications or improper software or interfacing.

4. **Remarks:**

- No other warranty is expressed or implied, except for the above mentioned.
- The remedies provided herein are the buyer's sole and exclusive remedies. ARRAY shall not be liable for any direct, indirect, special, incidental or consequential damages.

Limitation of warranty

1. Our warranties do not cover any damage resulting from unauthorized modification or misuse.
2. Unless mentioned elsewhere in this document, our warranty does not apply to fuses, probes, and problems arising from normal wear or user's failure to follow instructions.
3. Our warranties do not apply on any direct, incidental, special, or consequential damages.
4. The above warranties are exclusive and no other warranty is expressed or implied. ARRAY disclaims any implied warranties of MERCHANTABILITY, SATISFACTORY QUALITY, and FITNESS for any particular reasons.

1.3 Precaution of Operation

- Please carefully read the manual before operating this device.
- This manual is for reference only. Please consult your local service representative for further assistances.
- The contents of this manual may be amended by the manufacturer without notice.
- Never dismantle the equipment by any unauthorized personnel, or equipment may be damaged.
- The equipment has been strictly tested for quality before delivery from our factory. However, this equipment must not be used in dangerous situations where damage may result.

- This product should be placed in a safe area in case of unpredictable personnel use.
 - The rear protective conduct terminal needs to be connected to the actual earth ground or electric shock may occur.
 - The patent and related documents for the equipment belong to ARRAY and they aren't allowed to be used by others without permission.
-

1.4 Upkeep of M3500A

- Although M3500A multimeter is very durable and weather resistant, care should be taken not to expose it to severe impact or pressure.
 - Keep M3500A far from water and damp environment.
 - Calibration will be taken every year. Please contact with your local service representative for more information.
 - If the incorrect display or abnormal beeps occurred you should stop using the equipment at once.
 - Do not use the Meter around explosive gas or inflammable vapor.
 - Wipe the surface of M3500A multimeter with a piece of dry and clean cloth.
-

1.5 Safety Information



Warning! Please read through the following safety information before using the product.

To avoid possible electric shock or personal injury, please read and follow these guidelines carefully:

- Follow the guidelines in this manual and DO NOT use the Meter if the case is damaged. Check the Meter case and terminals, and make sure all the devices are in the proper positions.
- Do not apply excessive voltage to the Multimeter. Apply voltage within the rated range only.
- Use caution when measuring voltages above 30 V RMS, 42 V peak, or

60 V DC. These voltages pose an electric shock hazard.

- When using the probes, always keep your fingers behind the finger guards.
- Always connect the common test leads (black) before connecting the live test leads (red), and disconnect the live test leads (red) before disconnecting the common test leads (black). This will reduce the chance of an electric shock.
- Disconnect circuit power and discharge all high-voltage capacitors before testing resistance, continuity, diodes or capacitance.
- If you need to open the Meter case or replace any parts, read the instructions in this manual first. You must be a qualified personnel to perform this action.
- When replacing fuses, use only the same type and same rating as specified.
- Do not try to operate the Meter if it is damaged. Disconnect the power from the equipment and consult the local service representative. Return the product to ARRAY service department if necessary.

1.6 Symbols and Terms



This symbol indicates hazards that may cause damages to the instrument or even result in personal injury.



This symbol indicates high voltage may be present. Use extra caution before taking any action.



This symbol indicates the frame or chassis terminal presented need to be connected to the actual earth ground.



This symbol indicates "Protective Conductor Terminal".

 This symbol indicates earth (ground) terminal.

 This symbol indicates this product complies with the essential requirements or the applicable European laws or directives with respect to safety, health, environment and consumer protections.

? Note: Full M3500A specifications are included in Appendix A.

1.7 Inspection

Your product package is supplied with the following items:

- One M3500A Multimeter unit. (85 (H) x 210 (W) x 350 (D) mm, approx. 4.3 Kg)
- One power line cord.
- One USB cable.
- Standard Test Leads
- One CD (including this electronic User's Manual and software applications).
- Optional accessories as you ordered.
- Multi-Point scanner card. (Optional)
- GPIB interface card. (Optional)

1.8 Options and Accessories

The following options and accessories are available from ARRAY for use with the Model M3500A. Please refer to the following **Table 1-1**.

Part Name	Part Number
Multi-point Scanner Card	M3500-opt01
Thermocouple adapter	M3500-opt02
Adapters (Banana to BNC Adapter)	M3500-opt03
GPIB Card	M3500-opt04
RTD Probe Adapter	M3500-opt05

Table 1-1

2 Overview

This chapter will give you an overview of M3500A's basic features and guide you through the basics of M3500A digital multimeter. Users will become familiar with those features after reading this chapter.

2.1 Setting up Your M3500A Digital Multimeter

The purpose of this section is to prepare users for using M3500A DMM. You may want to check if you have all the parts with your multimeter. All our products are handled and inspected professionally before shipping out to our customers. If you find any damaged or missing parts, please contact your local service representative immediately and do not attempt to operate the damaged product. If users have any doubt about their products, they are encouraged to contact their local service representative.

2.1.1 To adjust the handle

You may adjust the carrying handle to suit your needs. The following figures show you how to adjust the handle.

I. Taking off the handle from the Multimeter

? Step 1? (Turn up the handle)

Pull slightly outward on both sides of the handle and slowly rotate it up as shown in **Figure 1-1**.

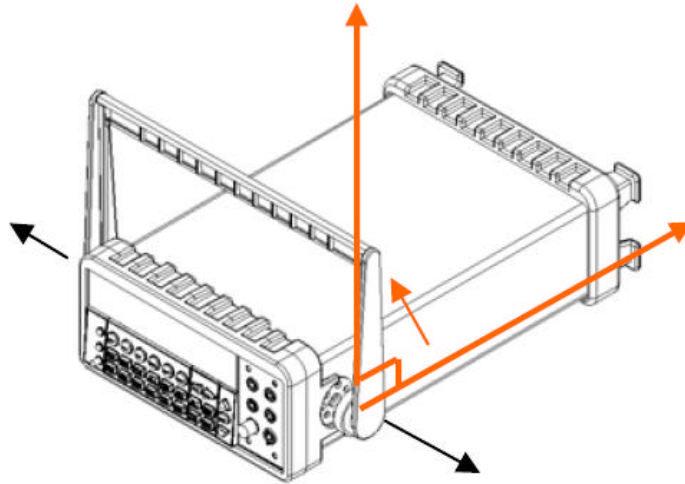

Figure 1-1

? Step 2? (Pull out the handle)

When the handle is turned up to 90° with the multimeter, pull out the handle from the multimeter as shown in **Figure 1-2**.

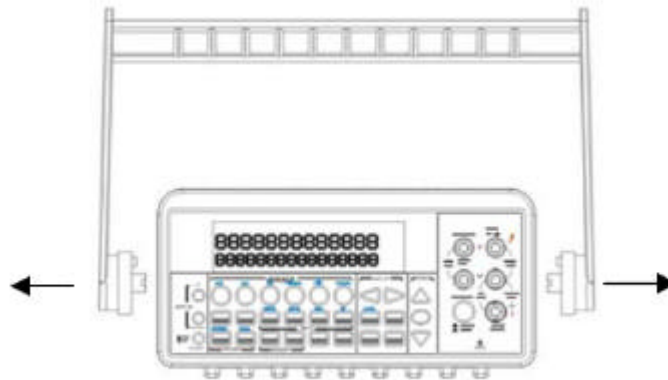

Figure 1-2

? . Adjusting the position for your convenience

Here are some example positions to suit users' needs.

? Position 1?

The default position is for packing as shown in **Figure 1-3**.

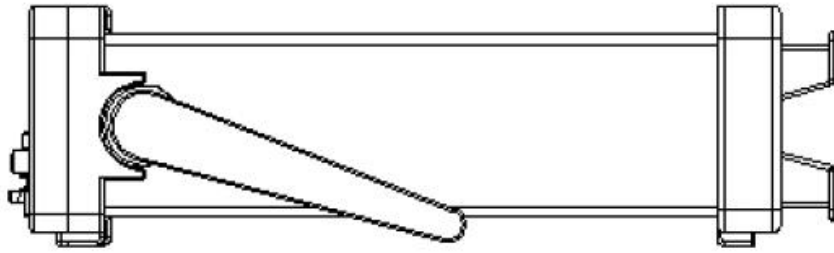

Figure 1-3

? Position 2?

The adjusted position is for operation as shown in **Figure 1-4**.

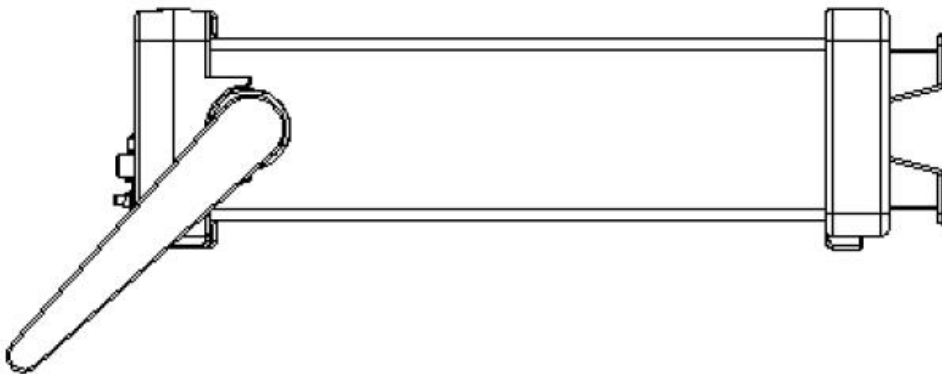

Figure 1-4

? Position 3?

The carrying position is with the handle as shown in **Figure 1-5**.

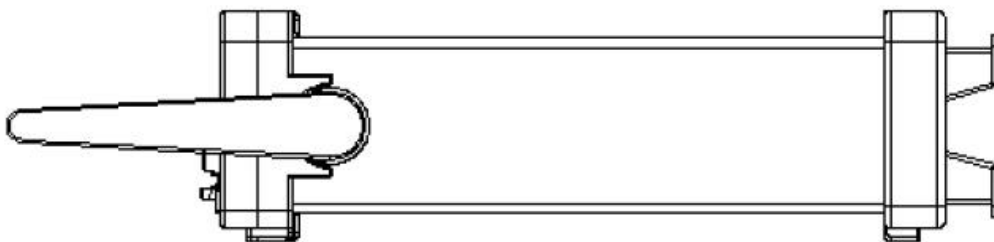

Figure 1-5

2.1.2 To connect the power

Check the power-line voltage on the rear panel to see if voltage setting is correct for your area. Change the setting if it is not correct or the fuse is broken. Please follow the steps below.

2.1.2.1 To convert the voltage



Warning! In some areas, the power supplied voltage is 240V or 120V; in others, the power supplied voltage is 220 V or 100 V. Please refer to your local power supplied voltage to see if you have the right setting.



Warning! Before changing the setting, make sure the multimeter is disconnected from the AC power. An incorrect voltage setting may cause severe damage to your instrument.



Warning! The power cord supplied with M3500A contains a separate ground wire for use with grounded outlets. When proper connections are made, instrument chassis is connected to power line ground through the ground wire in the power cord. Failure to use a grounded outlet may result in personal injury or death due to electric shock.

Suppose your condition is in AC 100V and you want to convert the voltage to the 220V. Follow these steps to change the voltage setting.

? Step 1?

Verify that the meter is disconnected as shown in **Figure 2-1**.

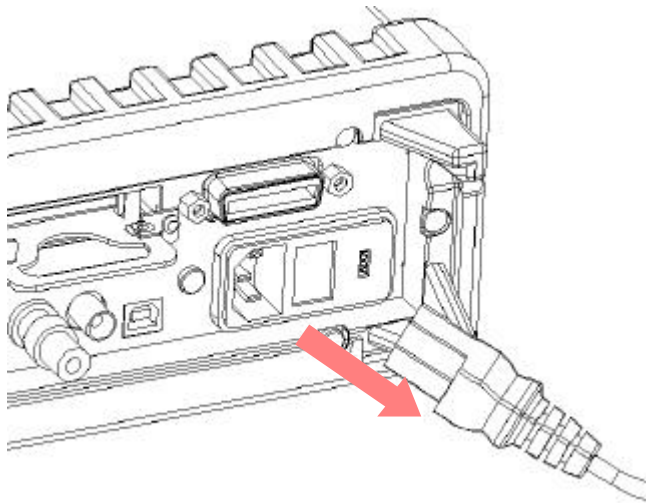

Figure 2-1

? Step 2?

Open the voltage setting selector cap as shown in **Figure 2-2**. (You might need a screwdriver to do so.)

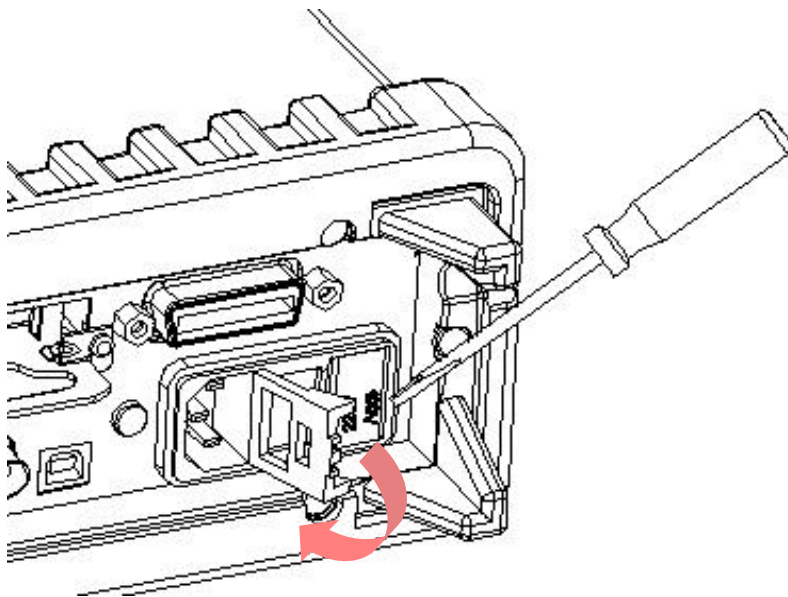

Figure 2-2

? Step 3?

Remove the red voltage setting selector from the right middle seam as shown in **Figure 2-3**. (You might need a screwdriver to do so.)

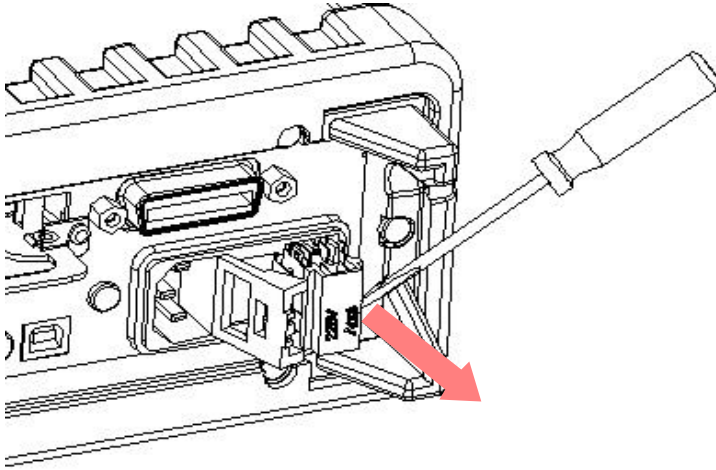

Figure 2-3

? Step 4?

Turn it over to 220V position as shown in **Figure 2-4**.

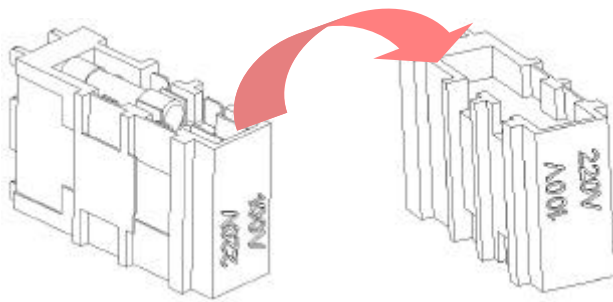

Figure 2-4

? Step 5?

Insert the voltage setting selector back into the socket and close the cap as shown in **Figure 2-5**.

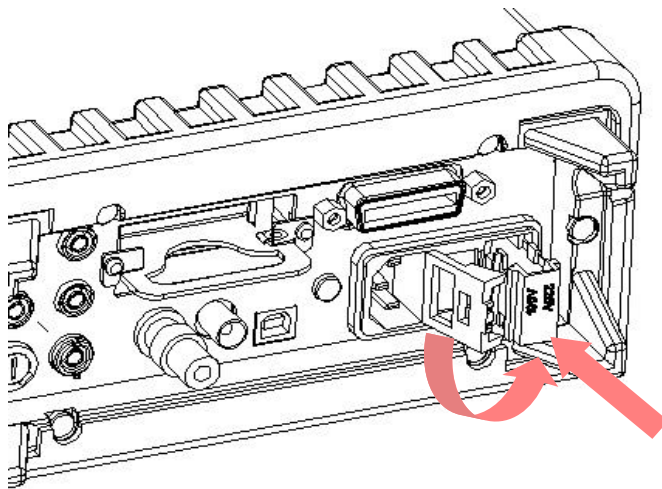

Figure 2-5

2.1.2.2 To change the fuse



Warning! Before replacing the power-line fuse, make sure the multimeter is disconnected from the AC power. You must be a qualified personnel to perform this action.



Warning! For continued protection against fire or instrument damage, only replace fuse with the same type and rating. If the instrument repeatedly blows fuses, locate and correct the cause of the trouble before replacing the fuse.

Verify that the power-line fuse is good. Replace the fuse if it is damaged. Use only the same type and same rating fuse noted on the rear panel. Please follow the steps below to change the fuse.

? Step 1?

Verify that the meter is disconnected as shown in **Figure 2-6**.

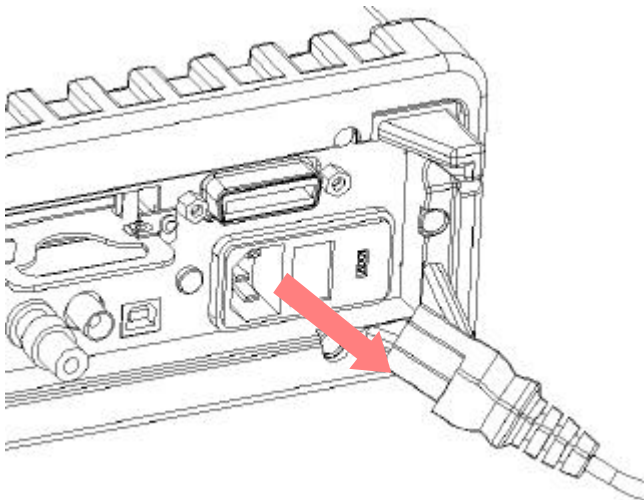

Figure 2-6

? Step 2?

Open the voltage setting selector cap as shown in **Figure 2-7**. (You might need a screwdriver to do so.)

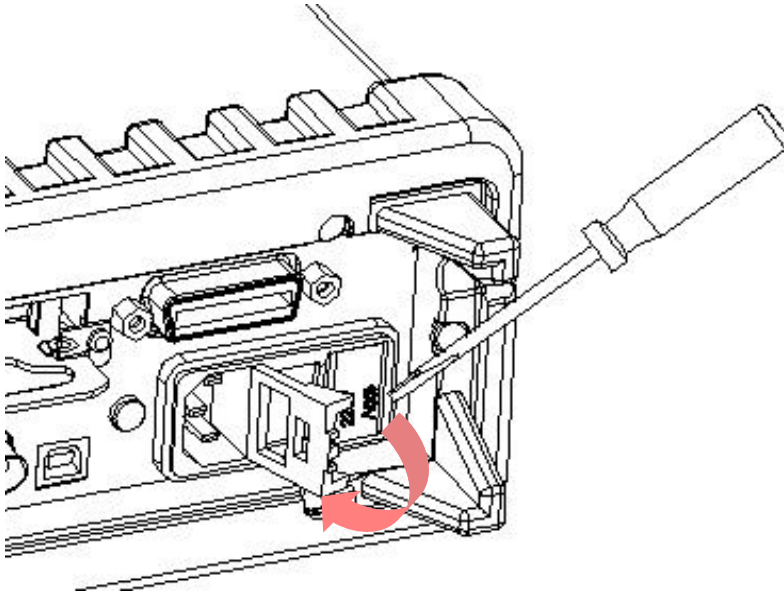

Figure 2-7

? Step 3?

Remove the red voltage setting selector from the right middle seam as shown in **Figure 2-8**. (You might need a screwdriver to do so.)

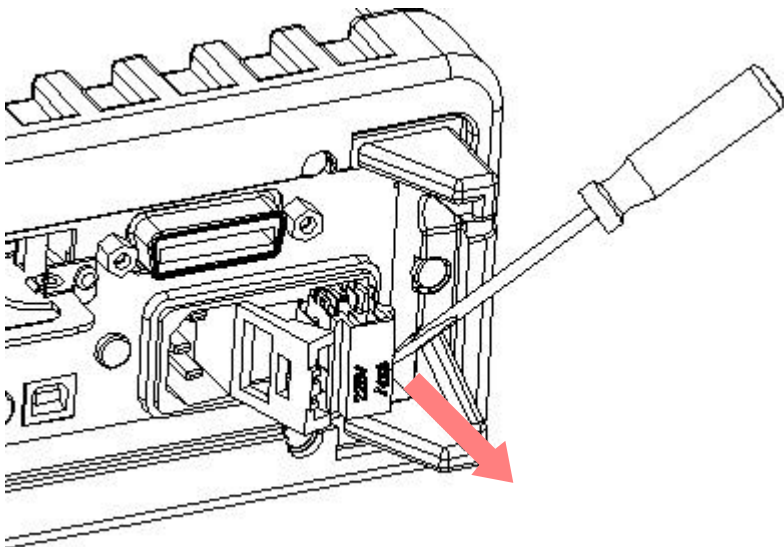

Figure 2-8

? Step 4?

Remove the broken fuse from the selector as shown in **Figure 2-9**.

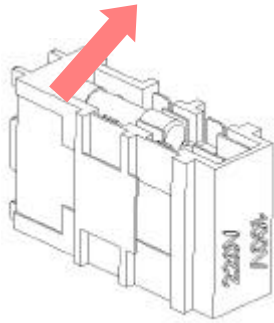

Figure 2-9

? Step 5?

Replace with the new fuse as shown in **Figure 2-10**.

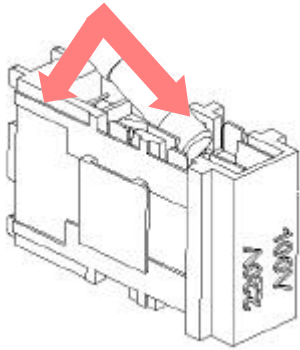

Figure 2-10

? Step 6?

Insert the voltage setting selector back into the socket and close the cap as shown in **Figure 2-11**.

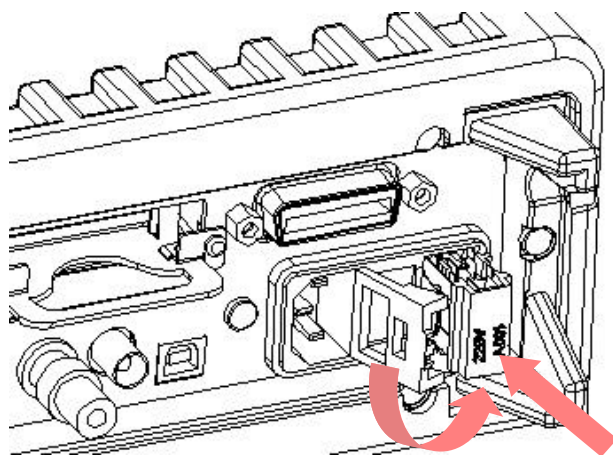

Figure 2-11

? Step 7?

Make sure the power switch on the front panel is in "Power OFF" condition before plugging as shown in **Figure 2-12**.

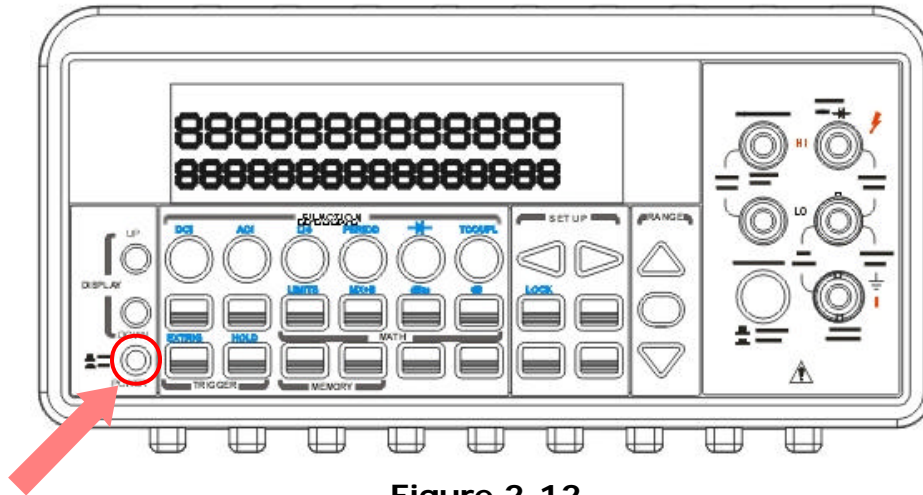

Figure 2-12

Power switch:



? Step 8?

After finishing the above procedures, you can plug in your power cord as shown in **Figure 2-13**.

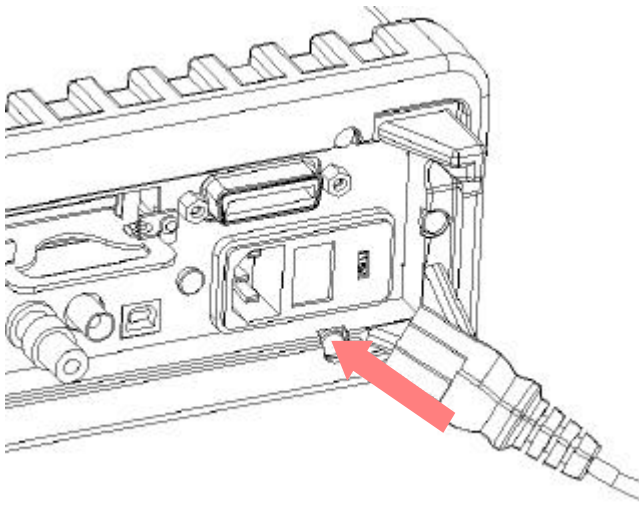

Figure 2-13

? Step 9?

Press on the power switch on the front panel for activating M3500A as shown in **Figure 2-14**.

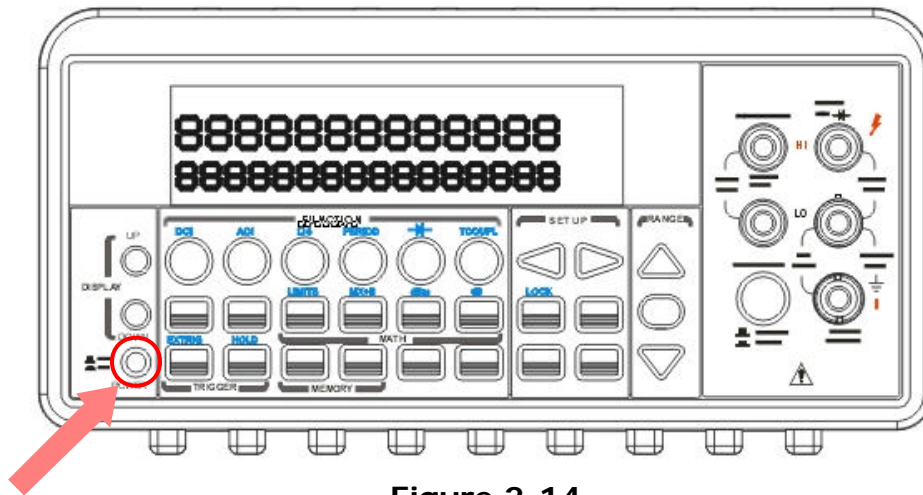

Figure 2-14

Power switch:

 - "POWER ON"

2.1.3 Factory Default When Power-ON

Table 2-1 shows the factory default of M3500A.

<i>Function</i>		<i>Default</i>
Function		DCV
Autozero		On
Frequency and Period Source		AC Voltage
Output Format		ASCII
Ratio		Off
AC Bandwidth	Input Frequency	20Hz

Voltage	AC Digits	5 ½
	DC digits	Slow 5 ½ (1 PLC)
	Range	Auto
Current	AC Digits	5 ½
	DC Digits	Slow 5 ½ (1 PLC)
	Range	Auto
Frequency and Period	Digits	5 ½
	Range	AUTO
	Rate	Medium (100ms)
Diode Test	Digits	5 ½
	Range	1mA
	Rate	0.1 PLC
Resistance (2-wire)	Digits	Slow 5 ½ (1 PLC)
	Range	Auto
Temperature	Digits	Slow 6 ½ (10 PLC)
	Thermocouple	K Type
Triggers	Source	Immediate
	Delay	Auto
Input Resistance		10MO

Table 2-1

2.2 Features

- Resolution: 6½ digits.
- 5*7 dot matrix VFD, dual displays with 3-color annunciators.
- 11 standard measurement functions & 8 math functions.
- 4 front ground terminal are connected to Chassis.
- Stability, Accuracy and Speed (2000RDGS/Sec at 4½ Digit, 50 RDGS/Sec at 6½ Digit in 60 Hz)
- Multi-Points Scanner Card: Up to 10 Channels. (Optional)
- RTD probe Adapter (optional) convenient to use.
- Built-in USB and GPIB (Optional) Interfaces.
- Easy & Free PC applications.

2.3 M3500A Function Introduction

For users to become familiar with the M3500A DMM, we will give a brief introduction to the basic operations of M3500A DMM. There are three major parts of M3500A: **(2.3.1) the front panel, (2.3.2) the display, and (2.3.3) the rear panel.** We will discuss each of them in the following sections.

2.3.1 The Front Panel

There are different buttons and terminals on the front panel. They are divided into the following groups: (DISPLAY & POWER), (FUNCTION, MATH, TRIGGER, MEMORY, SETUP, RANGE, INPUT TERMINALS), and (FILTER, DIGITS, LOCAL, and SHIFT) as shown in **Figure 2-15**.



Figure 2-15

1. Power & Display:

- Power: Activates M3500A DMM.
- Display: Shows model, version & condition by pressing round PREV & NEXT buttons.

2-1. First row without SHIFT button:

- DCV: Selects DC voltage measurement.
- ACV: Selects AC voltage measurement.
- O2: Selects 2-wire resistance measurement.
- FREQ: Selects frequency measurement.
- CONT: Selects the continuity test.
- TEMP: Selects RTD temperature measurement.

2-2. First row with SHIFT button:

- DCI: Selects DC current measurement.
- ACI: Selects AC current measurement.
- O4: Selects 4-wire resistance measurement.
- PERIOD: Selects period measurement.
- : Selects diode testing.
- TCOUPL: Selects thermocouple temperature measurement.

2-3. Second row without SHIFT button:

- FILTER: Enable or disable the digital filter.
- DIGITS: Changes resolution.
- RATIO: Enables the dcv: dcv ratio function.
- %: Calculates the ratio to a target value in percentage.
- MIN/MAX: Captures the minimum or maximum readings from the measurement.
- NULL: Activates the offset function in order to get the real measured reading.

2-4. Second row with SHIFT button:

- STEP: Scans from a channel to the next channel in delayed action when using the scanner card.
- SCAN: Enables scanning function when using the scanner card.
- LIMITS: Used for Setting upper and lower limit values for readings.
- MX+B: Used for calculating slope. X is the normal display reading. M and B are constants specified by user for scale factor and offset.
- dBm: Used for displaying voltage measurement in dBm power unit.
- dB: Used for displaying voltage measurement in decibel unit.

2-5. Third row without SHIFT button:

- SINGLE: Manually triggers the multimeter to make measurements.
- AUTO TRIGGER: Instructs the multimeter to make measurements continuously.
- STORE: Stores a specified number of subsequent readings.
- RECALL: Displays stored readings and buffer statistics. Use ?? or ?? searching buttons to toggle between reading number and reading.
- LOCAL: Cancels USB or GPIB remote mode.
- SHIFT (in blue): Used for accompanying other button with upper print in blue and converting function.

2-6. Third row with SHIFT button:

- EXTRIG: Selects external triggers as the trigger source via BNC port on the rear panel.
- HOLD: Holds reading.

3-1. The first row in SETUP section

- **??** : Scrolls through buffer, conceals or reveals the digits while measuring.

3-2. The second row in SETUP section:

- **ESC**: Cancels selection, moving back to measurement display.
- **ENTER**: Accepts selection, moving to next choice or back to measurement display.
- **LOCK**: Presses **SHIFT** then **ESC** button to prevent unpredictable operation on the panel. In order to release lock condition, please press **ESC** again.

3-3. The third row in SETUP section:

- **CONFIG**: Offers setting or adjusting function, relating some front panel buttons.
- **MENU**: Offers setting or adjusting function, not relating other front panel buttons.

4. RANGE:

- **↑** : Moves to higher range.
- **↓** : Moves to lower range.
- **AUTO**: Enables or disables auto-range.

5. Terminals: Selects input signal connections on front or rear panel.

6. Inserted Connections & Fuse Device:

- **4 Chassis Ground Connections**: Separate environmental noises.
- **HI** & **LO**: Used for all measurements, except DC and AC current. (Maximum input voltage: 1000V for voltage measurements. 200V for 4-wire measurement)
- **LO** & **I**: Used for making DC and AC current measurements.
- **Front Fuse**: Secures your Meter against damage of strong current pulse. (Maximum current: 3A, 250V)

2.3.2 The Display

M3500A has a 5x7 dot matrix, dual-display with three-color (White, Red and Yellow) annunciators for a better view. There are two rows in the dual-display screen. The upper row displays readings and units. A maximum 13 characters are allowed for upper row dot-matrix display. The lower row displays range of the measurements, condition or information about an ongoing configuration. A maximum 16 characters are allowed for lower row dot-matrix display. There are additional annunciators at upper side and right side of the display screen for indicating the state or the condition of an ongoing measurement. They are explained individually in the following sections.

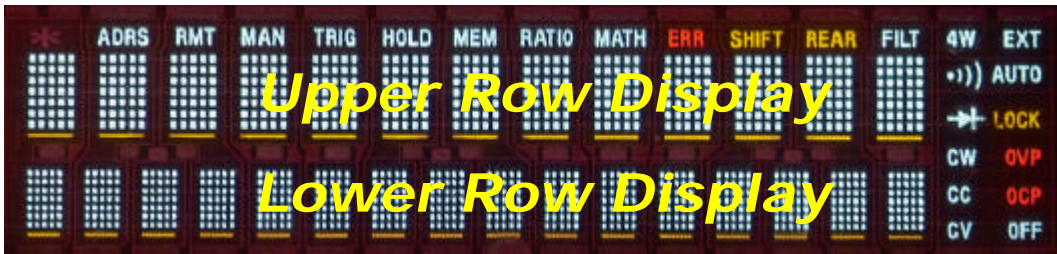

Figure 2-16

2.3.2.1 Annunciators at Upper Side



Figure 2-17

- ADRS: Indicates the multimeter is controlled via GPIB Interface.
- RMT (REMOTE): Indicates the remote state. (USB Interface)
- MAN: Indicates the manual range is taken.
- TRIG: Shows the single triggering is enabled.
- HOLD: Indicates reading hold function is enabled.
- MEM: Indicates the using of internal memory.
- RATIO: Indicates the dcv:dcv ratio operation.
- MATH: Indicates the "MATH" operation is taken.
- ERR: Error occurs.
- SHIFT: Indicates SHIFT button is pressed.
- REAR: The rear panel input terminal is selected for the measurement.

- FILT: The digital filter is started.

2.3.2.2 Annunciators at Right Side

- 4W: Indicates 4 –wire mode is selected for resistance measurement.
- $\rightarrow))$: Indicated the continuity testing is enabled.
- $\rightarrow|$: Indicates the diode testing operation is taken.
- CW: Not used for Model M3500A.
- CC: Not used for Model M3500A.
- CV: Not used for Model M3500A.
- EXT: Indicates the External Trigger Mode is enabled.
- LOCK: Indicates the front panel menu operation is locked.
- OVP: Not used for Model M3500A.
- OCP: Not used for Model M3500A.
- OFF: Indicates the front panel display is turned off.

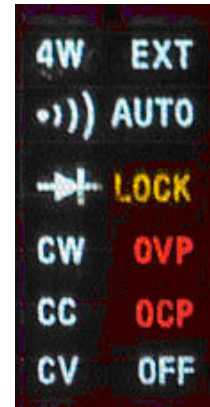

Figure 2-18

2.3.3 The Rear Panel

The rear panel of the M3500A is shown in **Figure 2-19**. This figure includes important abbreviated information that should be reviewed before using the instrument.

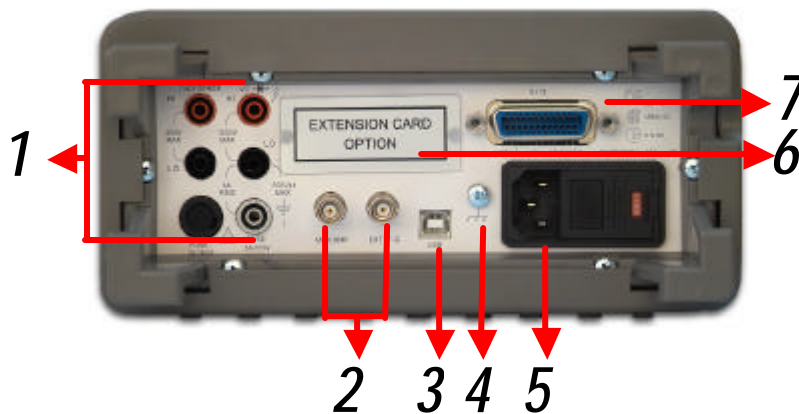

Figure 2-19

1. Inserted Connections & Fuse Device:

- **HI** & **LO**: Used for all measurements, except AC & DC current and temperature.
- **LO** & **I**: Used for making DC and AC current measurements.
- **Rear Fuse**: Secures your Meter against damage of strong current pulse.

2. BNC Connections:

- **VM COMP**: Voltmeter Complete Output Terminal. Outputs a low-true pulse after the completion of each measurement.
- **EXT TRIG**: External Trigger Input Terminal. Inputs a low-true pulse from a remote interface.

3. USB Connection: Connects a remote computer for changing operation environment instead of the front panel control.

4. Protective Conductor Terminal.

5. Power Module: Contains the AC line receptacle, power line fuse, and line voltage setting. Configured for line voltages of 100/220V or 120/240V. (Depend on the power utility in your area.)

6. Option Slot: Designed for installing an optional multi-point scanner card (Model: M3500-opt01).

7. Option GPIB/IEEE488 Connection: Connects a remote computer with an IEEE488 cable for changing operation environment instead of the front panel control (Model: M3500-opt04).

3 Basic Measurement Function

This chapter introduces some basic measurement functions in M3500A. You will learn how to use your M3500A multimeter to measure voltage, current, resistance, frequency, period, continuity, diode and temperature in this chapter.

3.1 Voltage Measurements (DC & AC)

The ranges for DC voltage measurements in M3500A are 100mV, 1V, 10V, 100V and 1000V. For AC voltage measurements, the ranges are 100mV to 750V RMS, or 1000V peak. **Figures 3-1** and **3-2** show the locations of the buttons needed and message display for voltage measurement. **Figure 3-3** shows the location of the input terminals on the rear panel.



Warning: Do not apply more than 1000V (peak) to the multimeter. Applying excess voltage may damage your meter, or cause possible electric shock or personal injury.

? **Note:** To eliminate the thermal EMFs due to the differences between two metals, use copper leads to connect your source signal to the meter.

How to measure voltage

Selects input signal connections on front or rear panel.

Connect the test leads to the terminals as shown in **Figure 3-1** (DC) or **Figure 3-2** (AC).

Set RESOLUTION of DCV (Refer to 4.1.3), BAND WIDTH of ACV (Refer to 4.1.2.1) or skip this step if default is to be used.

Press DCV or ACV button for DC or AC voltage measuring.

Select the auto-range function by pressing AUTO button on the front panel or use buttons to select desired range.

Connect test leads to your source signal and observe the reading shown on the display. If the input signal is beyond the allowed range, an overflow message "OVL" will be displayed.

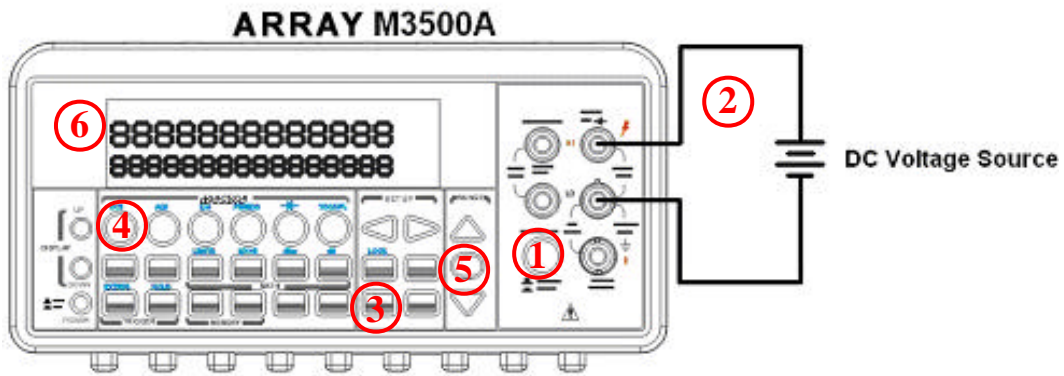

Input Resistance = 10M Ω on 1000V and 100V ranges;
> 10G Ω on 10V, 1V and 100mV ranges.

Figure 3-1

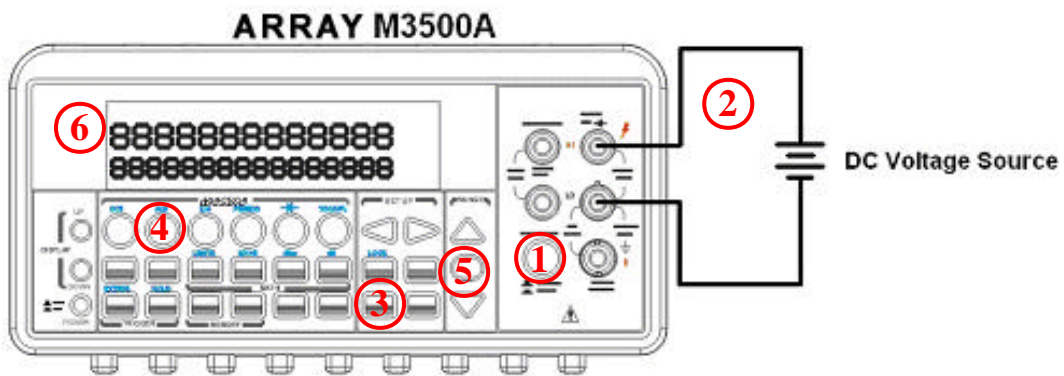

Input Resistance = 10M Ω on 1000V and 100V ranges;
> 10G Ω on 10V, 1V and 100mV ranges.

Figure 3-2

? Note: The rear panel terminals can also be used via the same procedures as the front panel terminals. (Refer to Figure 3.3)

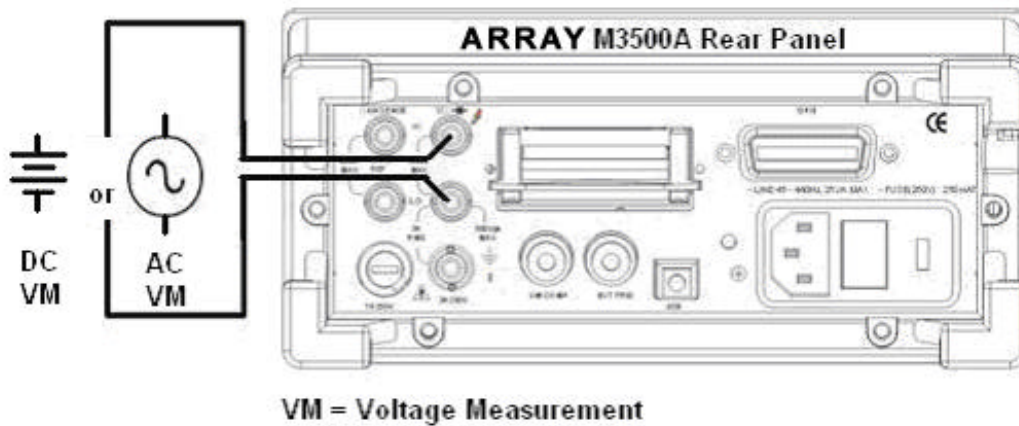

Figure 3-3

3.2 Current Measurements (DC & AC)

The ranges for DC current measurements in M3500A are 10mA, 100mA, 1A and 3A. For AC current measurements, the range is 1A with a sensitivity of 1 μ A to 3A RMS with a sensitivity of 10 μ A. **Figure 3-4** and **3-5** show you how to measure DC/AC currents in M3500A.



Warning! The maximum input current allowed is 3A, 250V. Do not apply excess current to your meter to avoid damaging the fuse of current input.

? **Note:** To eliminate the thermal EMFs due to the differences between two metals, use copper leads to connect your source signal to the meter.

How to measure current

Selects input signal connections on front or rear panel.

Connect the test leads to the terminals as shown in **Figure 3-4**.

Set RESOLUTION of DCI (Refer to 4.1.3), BANDWIDTH of ACI (Refer to 4.1.2.1) or skip this step if default is to be used.

Press SHIFT+DCV or SHIFT+ACV buttons for DCI or ACI measurement.

Select the auto-range function by pressing AUTO button on the front

panel or use ? and ? buttons to select desired range.
 Connect test leads to your source signal and observe the reading shown on the display. If the input signal is greater than the allowed range, an overflow message "OVL" will be displayed.

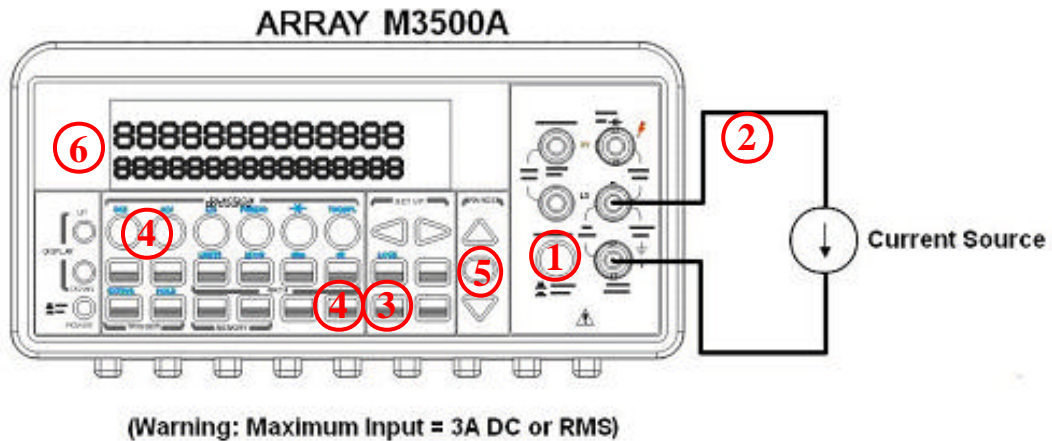

Figure 3-4

? Note: The rear terminal panel also can be used via the same procedures as the front panel. (See Figure 3-5)

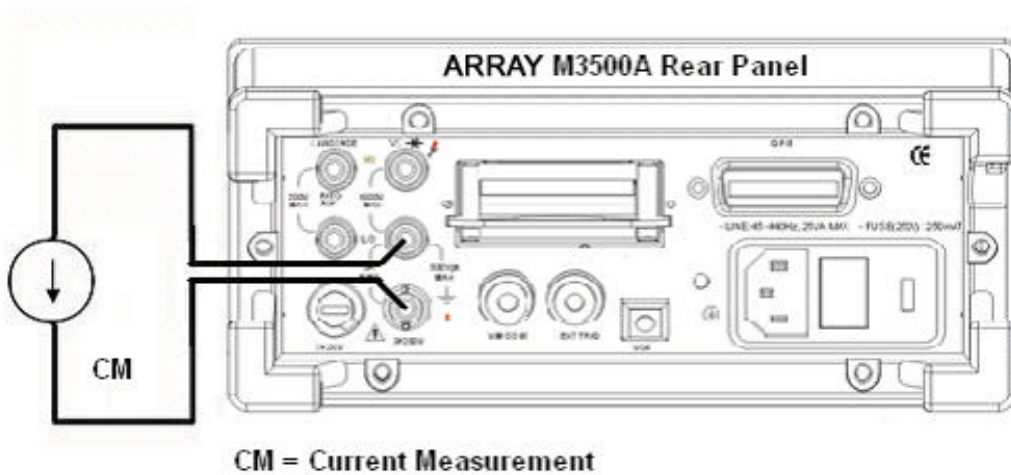

Figure 3-5

3.3 Resistance Measurements (2 & 4-wire)

The ranges for resistance measurement are 100 Ω , 1K Ω , 10k Ω , 100k Ω , 1M Ω , 10M Ω , and 100M Ω , with a sensitivity of 100 $\mu\Omega$ (on 100 Ω range.) There are two modes for measuring the resistance: 2-wire mode as shown in **Figure 3-6** and 4-wire mode as shown in **Figure 3-7**. With 4-wire mode, the test current is measured from the test resistance through one pair of the test leads, and the test voltage across the resistance under test is measured from another set of the test leads. As a result, the 4-wire mode is more accurate for low resistance measurements. The tradeoff is the longer settling time for 4-wire mode. **Figure 3-8** and **3-9** show the input terminal connections on the rear panel for 2-wire mode and 4-wire mode respectively.

How to measure resistance

Selects input signal connections on front or rear panel.

Connect the test leads to the terminals as shown in **Figure 3-6** (2-wire) or **Figure 3-7** (4-wire).

Set RESOLUTION (Refer to 4.1.3) or skip this step if default is to be used.

Press O2 button for 2-wire measurement or SHIFT + O2 buttons for 4-wire measurement.

Select the auto-range function by pressing AUTO button on the front panel or use Δ and ∇ buttons to select the desired range.

Connect test leads to your source signal and observe the reading shown on the display. If the input signal is greater than the allowed range, an overflow message "OVL" will be displayed.

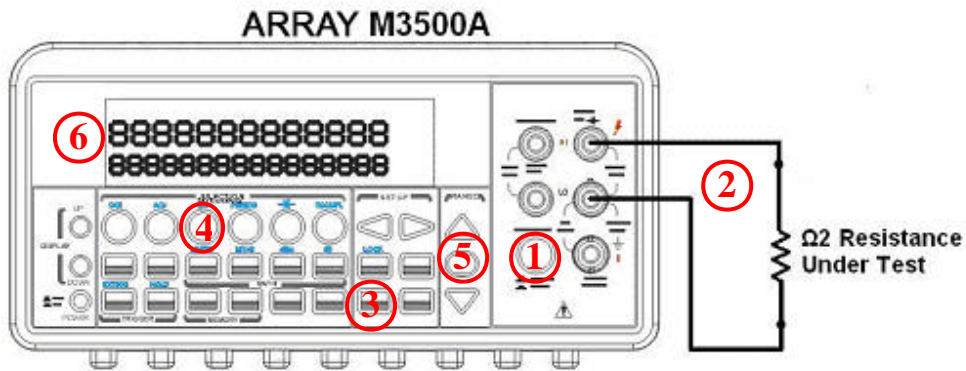

Note: Source current flows from the INPUT HI to INPUT LO terminals.

Figure 3-6

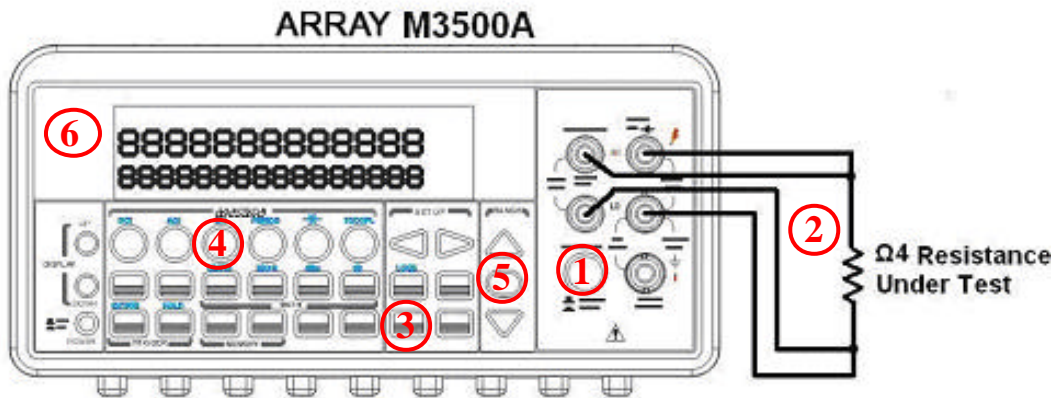

Note: Source current flows from the INPUT HI to INPUT LO terminals.

Figure 3-7

? Note: The rear terminal panel also can be used via the same procedures as the front panel as shown in **Figures 3-8 and 3-9**.

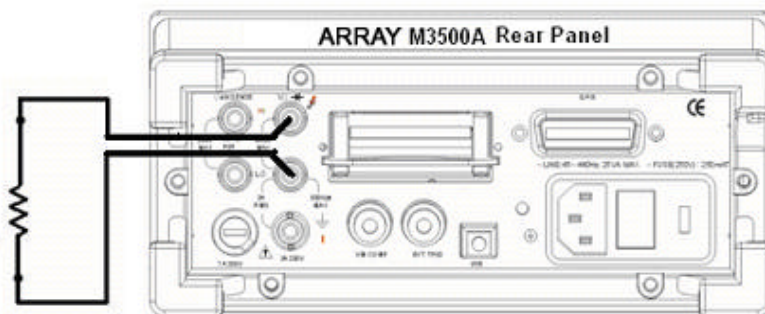

2-wire resistance measurement

Figure 3-8

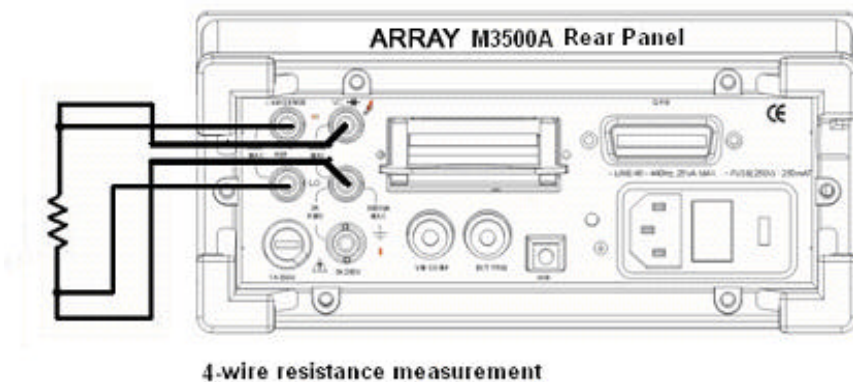

Figure 3-9

3.4 Frequency & Period Measurements

M3500A uses an on-board counter with 25MHz to measure the frequency (period). The measurement band is from 3Hz to 300kHz (or 333 ms to 3.3 μ s) and the measurement voltages range from 100mV to 750 V in AC. The default for "RANGE" is auto-range.

⚠ Warning! The maximum input allowed is 1000V. Applying excess voltage may damage your meter.

How to measure frequency and period

Selects input signal connections on front or rear panel.

Connect the test leads to the terminals as shown in **Figure 3-2**.

Set RESOLUTION (Refer to 4.1.1) and INPUT JACK. Or skip this step if default is to be used.

Press **FREQ** button for frequency measurement or **SHIFT + FREQ** buttons for period measurement.

Select the auto-range function by pressing **AUTO** button on the front panel or use **? / ?** buttons to select the desired range.

Connect test leads to your source signal and observe the reading shown on the display. If the input signal is beyond the allowed range, an overflow message "OVL" will be displayed.

? Note: The rear terminal panel also can be used via the same procedures as the front panel. (Please refer to **Figure 3-3**)

3.5 Continuity Measurements

M3500A uses 1 K Ω range for the continuity measurement. The meter beeps when the test resistance is less than the threshold resistance. The default threshold resistance is 10 Ω , but user can set the threshold resistance to anything between 1 Ω and 1 K Ω . The resistance value set by user is stored in a volatile memory and will be cleared after the meter has been turned off. The source current for the continuity measurement is 1 mA.

 **Warning!** The maximum input voltage allowed is 1000 V. Applying excess voltage may damage the meter and cause unpredictable hazards.

How to measure the continuity

Selects input signal connections on front or rear panel.

Selects input signal connections on front or rear panel.

Connect the test leads to the terminals as shown in **Figure 3-10**.

Set threshold resistance via pressing CONFIG + CONT buttons. (Or skip this step if default resistance is to be used) When ready, press ENTER button.

Press CONT button.

The measured value will be shown on the display automatically. Meter “beeps” when measured resistance value is lower than threshold value.

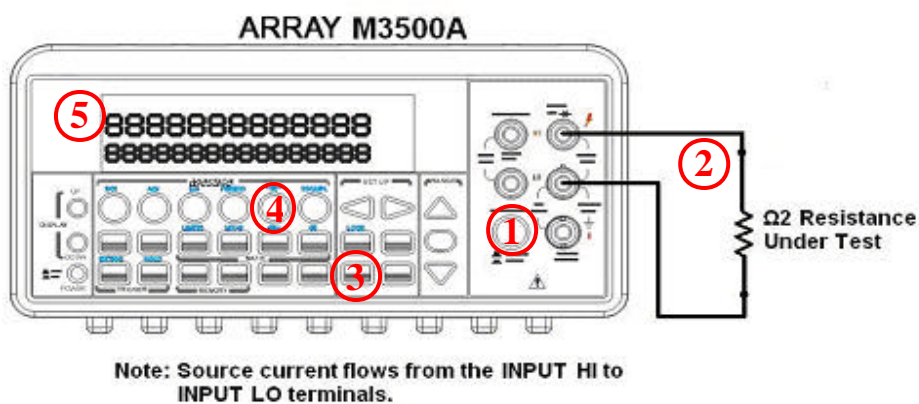

Figure 3-10

3.6 Diode Measurements

M3500A uses a current source of 1 mA for diode testing. The maximum resolution is 10 μV on a fixed range of 1 V DC. The default threshold voltage is fixed between 0.3 and 0.8 volts and the reading rate is fixed at 0.1 PLC (The voltage bound is adjustable from 0.01V up to 1.2V.). A “Beep” sound will appear when the diode measured value is in the range.

Warning! Positive end of the source signal is to be connected to HI of the input terminals, and the negative end to LO of the input terminals.

How to measure diode

Selects input signal connections on front or rear panel.

Connect the diode to the terminals as shown in **Figure 3-11**. For forward bias, connect the probe from input terminal “HI” to the positive end of the diode, and connect the probe from input terminal “LO” to the negative end of the diode.

Set voltage bound via pressing CONFIG + SHIFT + CONT buttons. When ready, press ENTER. (Or skip this step if you wish to use the default voltage bound.)

Press SHIFT + CONT buttons to select the diode testing function and observe the reading on the display.

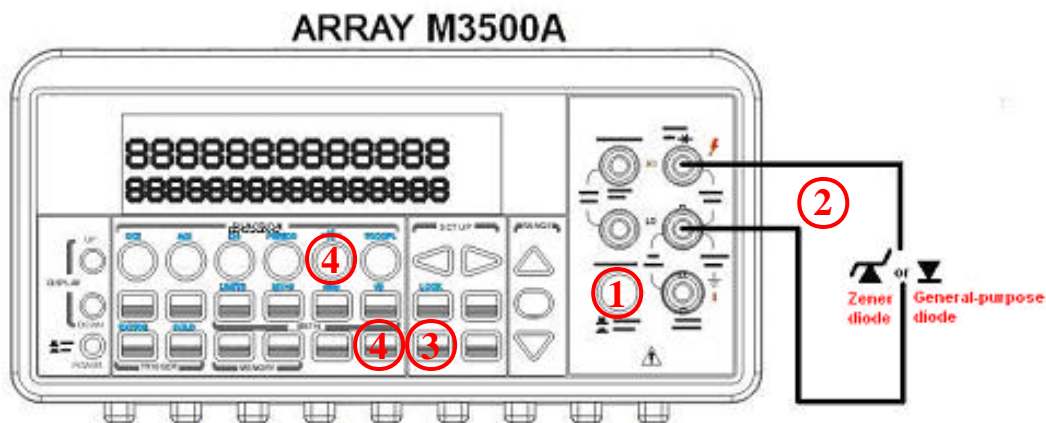

Note: Source current flows from the INPUT HI to INPUT LO terminals.

Figure 3-11

3.7 Temperature Measurements

The M3500A supports thermocouples and resistance temperature detector (RTD) types of probes. For thermocouples, M3500A supports 7 types: E, J, K, N, R, S and T. Please refer to **Table 3-2** for their temperature ranges. Be sure that the temperature function is configured for the right sensor type before making measurements (Refer to 4.1.8 for how to make the sensor configuration).

In general, RTDs have a better accuracy and long-term stability than thermocouples. The default RTD type in M3500A is PT100 and the thermocouple is type K.

<i>Sensor Type</i>	<i>Temperature Range(°C)</i>	<i>Temperature Range(°F)</i>
E	-270~1000	-518~1832
J	-210~1200	-140~2192
K	-270~1372	-518~2502
N	-270~1300	-518~2372
R	-50~1768	-122~3236
S	-50~1768	-122~3236
T	-270~400	-518~752
RTD (PT 100)	-200~850	-392~1562

Table 3-2

3.7.1 Thermocouple Measurements

Connect the thermocouple adapter to the banana jacks on the front panel. The difference between each type is subject to the patch thermal leads.

? **Note: Only connection via the front panel can be used for temperature measurements.**

How to measure thermocouple

Use terminals switch to select terminals on the front panel.

To measure thermocouple must be via thermocouple adapter and the low thermal patch leads as shown in **Figure 3-12**. (When the mentioned modules are well connected as the following figure, please go to the next step.)

Configure the thermocouple type and unit using CONFIG + SHIFT + TEMP, such as K TYPE and °C. When ready, press ENTER button.

Press SHIFT + TEMP buttons.

Take the reading on the display.

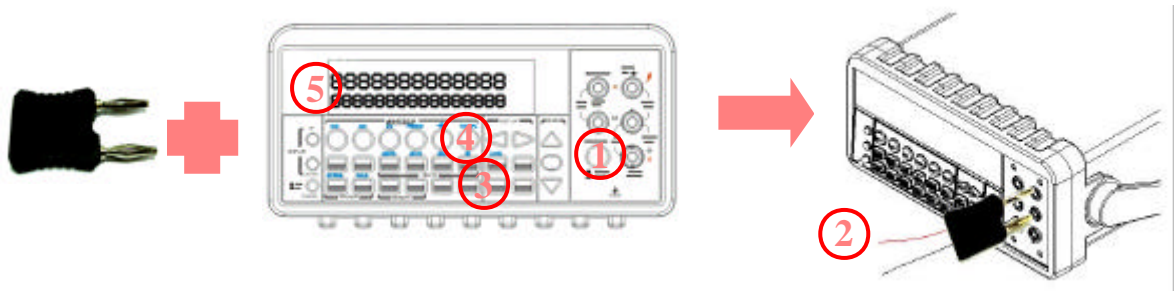

Figure 3-12

3.7.2 RTD Measurements

There are three kinds of temperature measurements with RTDs: 2-wire, 3-wire and 4-wire measurements. You will find connection instructions and measuring procedures in the following sections.

3.7.2.1 2-Wire RTD Measurements

How to measure temperature with 2-Wire RTD

The following **Figure 3-13** shows theory diagram of 2-Wire RTD measurement.

Use terminals switch to select front terminals.

Insert a specified adapter into the front terminals. Connect the low thermal patch leads to the adapter as shown in **Figure 3-14**.

Configure sensor type and unit using CONFIG + TEMP and ? or ? .
When ready, press ENTER button.

Press TEMP button.

Place RTD in the desired position and take the reading on the display.

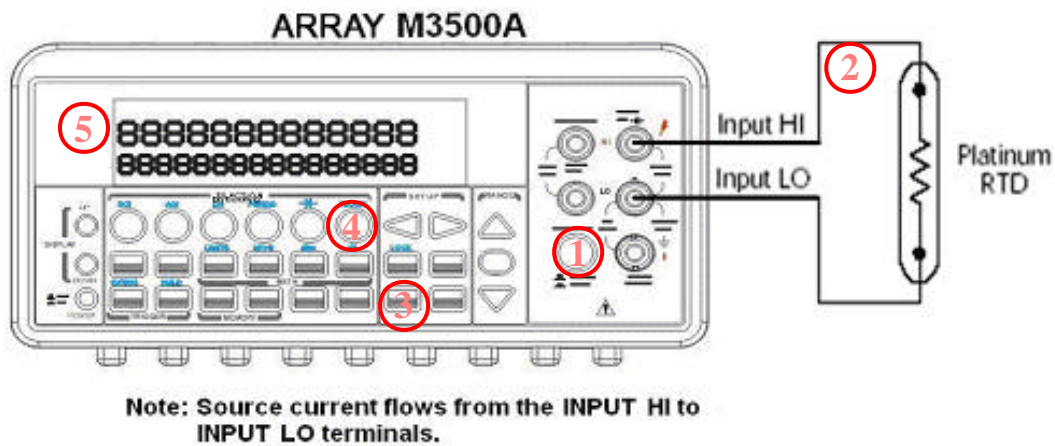
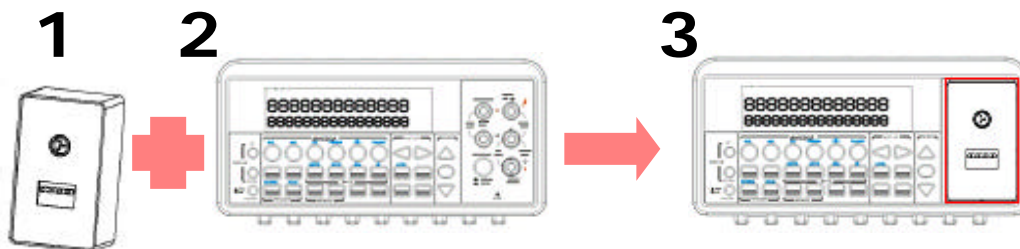

Figure 3-13



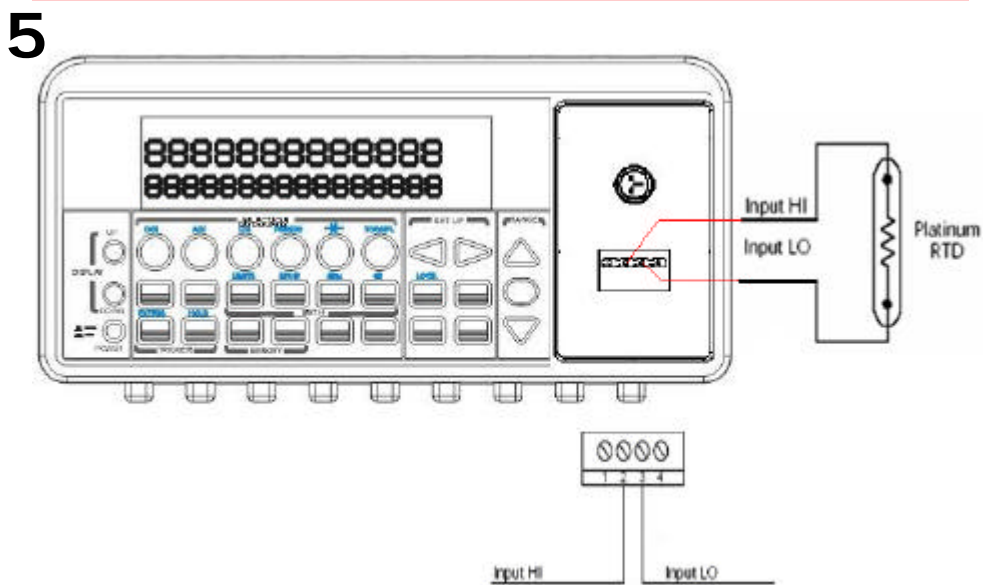
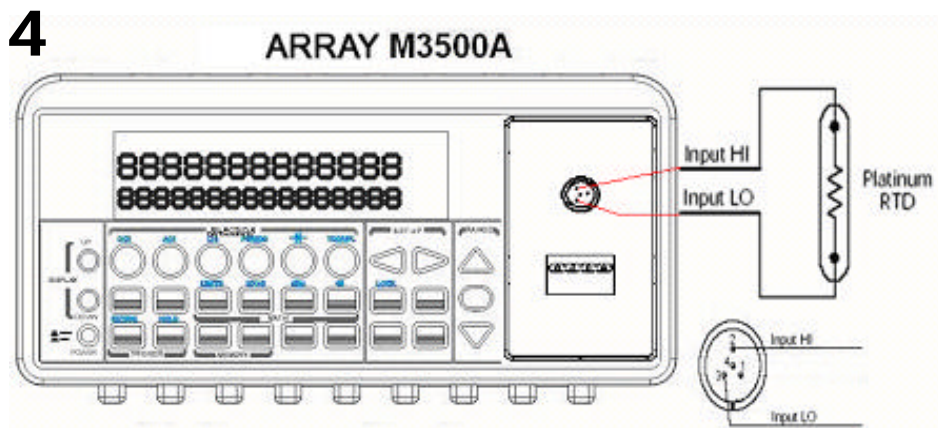

Figure 3-14

3.7.2.2 3-Wire RTD Measurements

How to measure temperature with 3-Wire RTD

The following **Figure 3-15** shows theory diagram of 3-Wire RTD measurement.

Use terminals switch to select front terminals.

Insert a specified adapter into the front terminals. Connect the low thermal patch leads to the adapter as shown in **Figure 3-16**.

Configure sensor type as you would with 4-wire RTD and unit using CONFIG + TEMP and ? or ? . When ready, press ENTER button. Press TEMP button. Place RTD in the desired position and take the reading on the display.

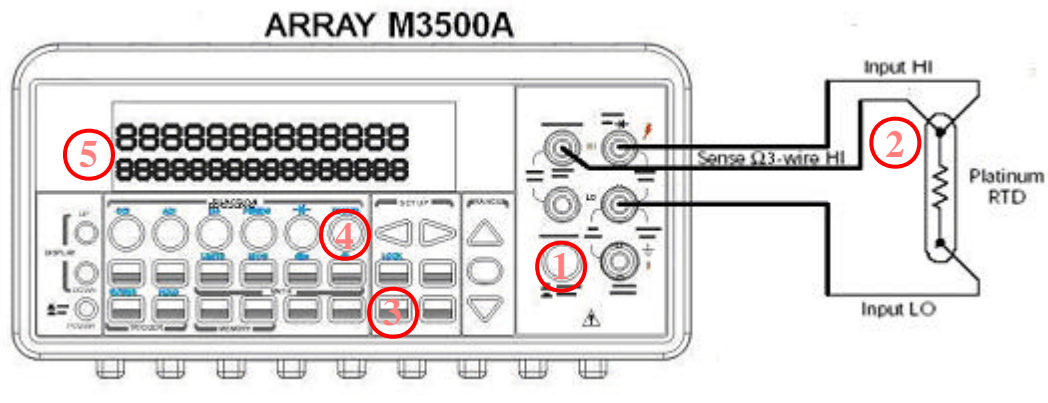
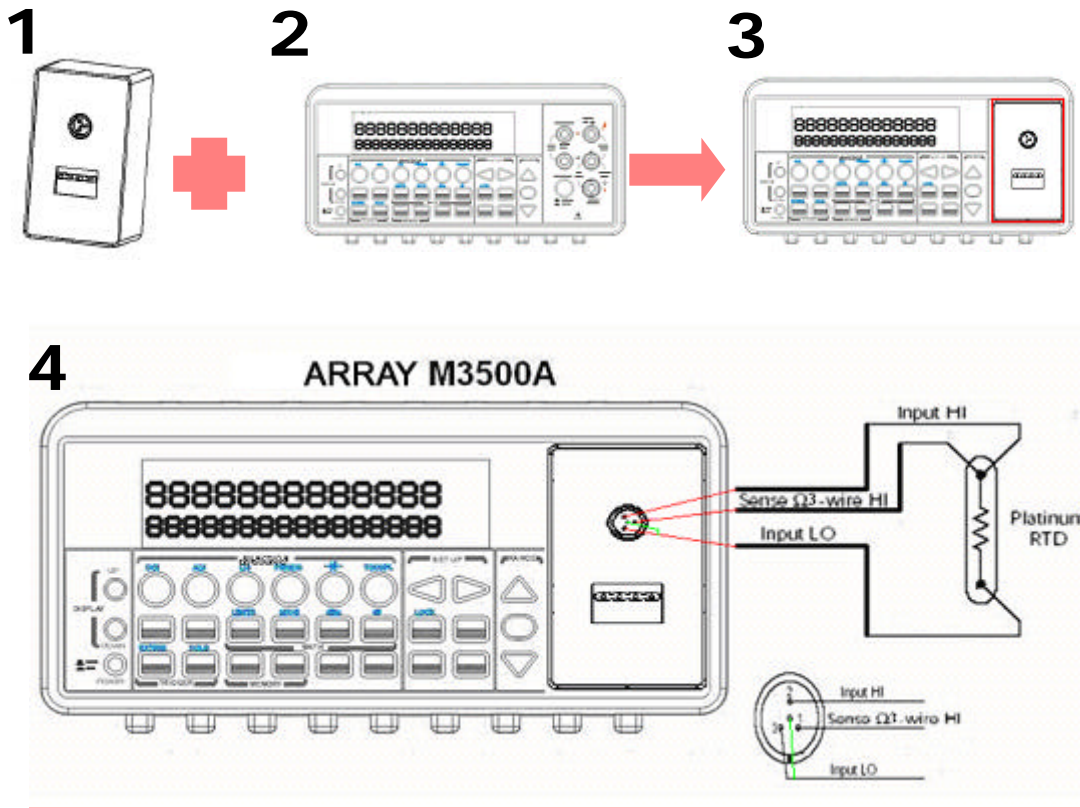

Figure 3-15



5

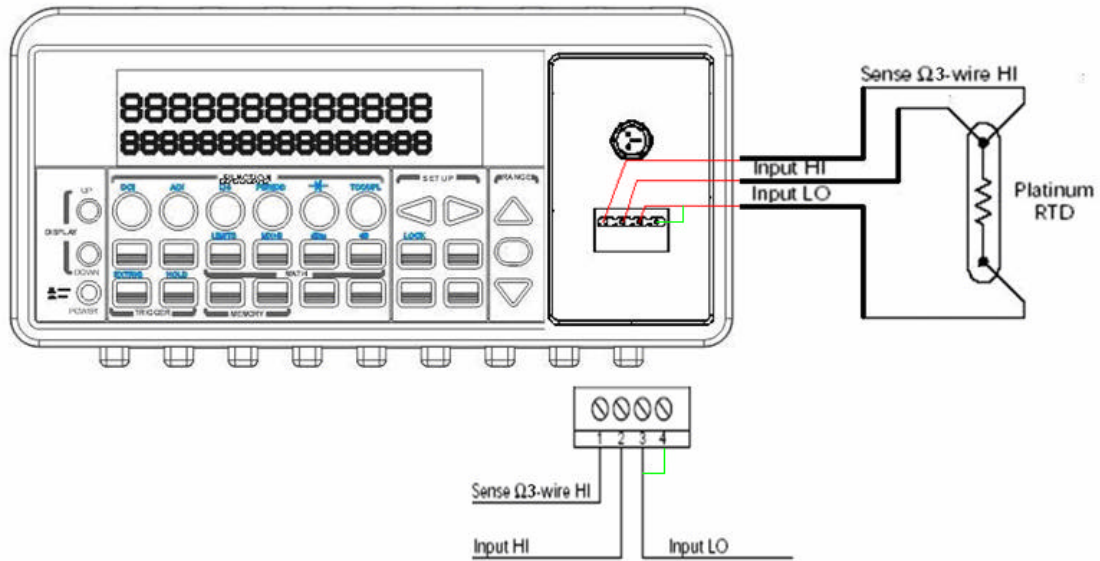

Figure 3-16

3.7.2.3 4-Wire RTD Measurements

How to measure temperature with 4-Wire RTD

The following **Figure 3-17** shows theory diagram of 4-Wire RTD measurement.

Use terminals switch to select front terminals.

Insert a specified adapter into the front terminals. Connect the low thermal patch leads to the adapter as shown in **Figure 3-18**.

Configure sensor type and unit using CONFIG + TEMP and ? or ? .

When ready, press ENTER button.

Press TEMP button.

Place RTD in the desired position and take the reading on the display.

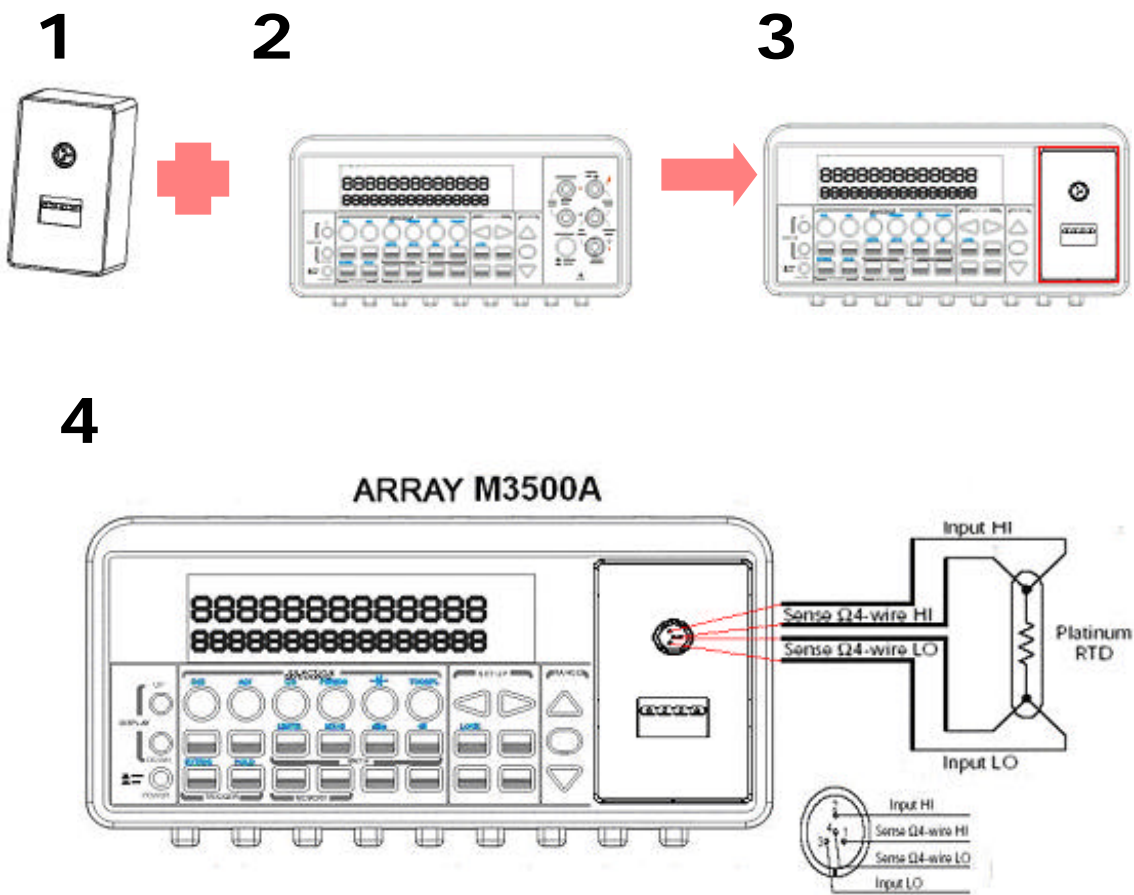
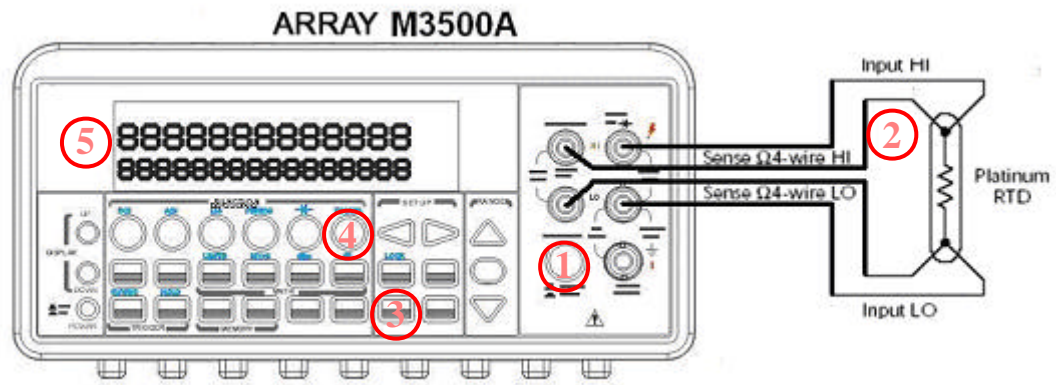

5

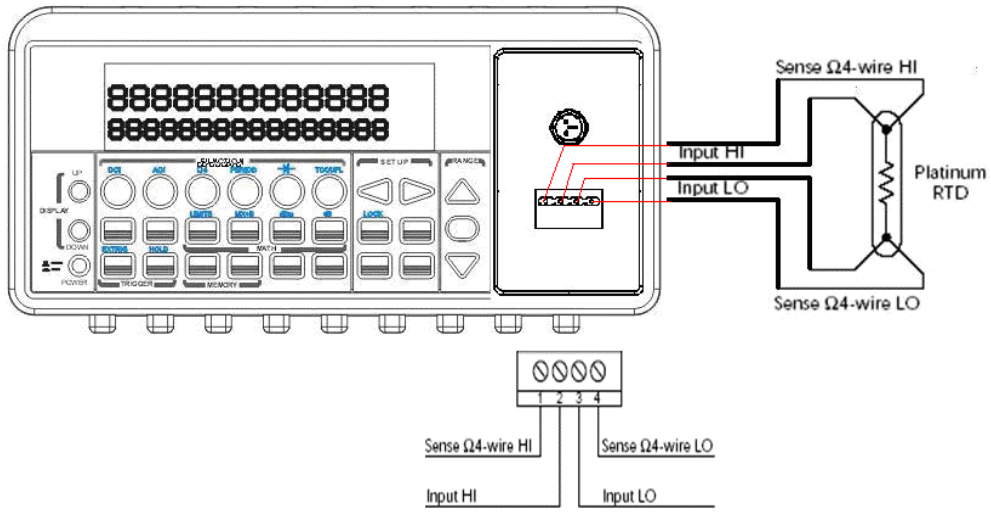

Figure 3-18

4 Front Panel Operations

This chapter contains information about how to change the parameters and settings for your measurements and all the details about each feature and function.

4.1 Measurement Configuration

The following information will guide you through ways to configure measurement functions. It provides you the flexibility to change any parameter in any measurement function when needed, including ADC setting, filter, resolution setting (digits), DC input resistance, threshold resistance (continuity), range (manual & auto), rate (integration time), sensor type for temperature measurements, remote interface selection and input terminal switch.

4.1.1 Set ADC (Auto Zero & Auto Gain)

Zero and Gain

The purpose of Auto Zero and Auto Gain functions are used for minimizing the offset influence on your measurements. When Auto Zero or Auto Gain is enabled, M3500A takes the input signal reading as a base value and then internally disconnects the input signal, and takes an offset reading (a null offset). It then subtracts the offset from the base to get an accurate measurement.

$$\text{Displayed reading} = \text{Base value (input signal)} - \text{Offset value}$$

When the Auto Zero or Auto Gain is enabled the meter takes an offset reading for each subsequent measurement. However, when Auto Zero or Auto Gain is disabled, the meter only takes one offset reading each time when you change the function settings. User can set "PERIOD" to change the time interval for taking an offset reading.

Defaults

The default settings for Auto Zero and Auto Gain are enabled. The user selected values for Auto Zero and Auto Gain are stored in a volatile memory and the default settings will be restored when the meter is power-off.

How to set Auto Zero and Auto Gain

You can change the Auto Zero and Auto Gain setting through the front panel or through the remote interface operation.

Front Panel Operation

The following steps show how to set Auto Zero and Auto Gain directly through the front panel.

Be aware that Auto Zero setting is always affected by the resolution setting. Whenever the resolution is altered, Auto Zero may be changed accordingly. The relation between resolution and Auto Zero is shown in **Table 4-1**.

Press MENU and then ENTER on SET ADC. If "SET ADC" is not shown on the display, use ? and ? buttons to locate it. Press ENTER on ZERO or GAIN. Again, use ? and ? buttons to locate it if it is not shown on the display. Press ENTER on AUTO ZERO or AUTO GAIN option and then use ? and ? to the "ON" or "OFF". Press "ENTER" by your choice. The locations of these buttons are shown with red rectangle frames in **Figure 4-1**.

Procedures: MENU? SET ADC ? ZERO? AUTO ZERO {ON|OFF}
MENU? SET ADC ? GAIN? AUTO GAIN {ON|OFF}

<i>Resolution</i>	<i>Auto Zero</i>	<i>Integration Time(PLC)</i>
Fast 4 ½ digits	Off	0.02
Slow 4 ½ digits	On	0.1

Fast 5 ½ digits	Off	0.1
Slow 5 ½ digits	On	1
Fast 6 ½ digits	On	1
Slow 6 ½ digits	On	10

Table 4-1

? Note: To change resolution, refer to Section 4.1.3: Resolution Setting in this chapter.

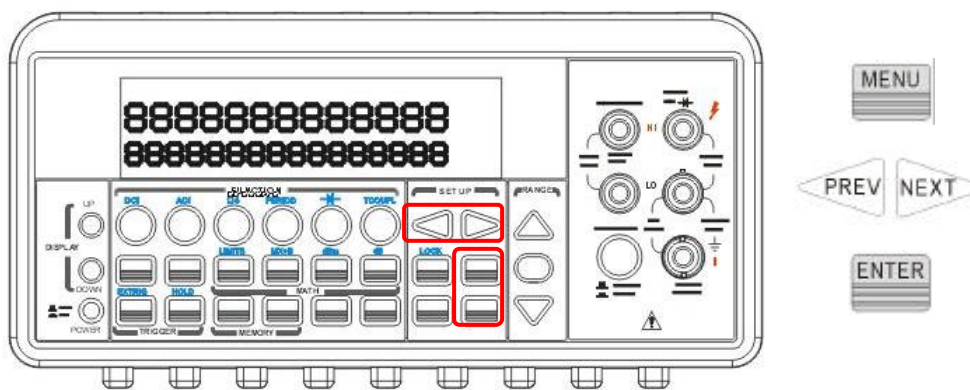

Figure 4-1

Remote Interface Operation

To set Auto Zero and Auto Gain through the remote interface, use the following commands:

SENSE:ZERO:AUTO { OFF|ONCE|ON}

SENSE:GAIN:AUTO { OFF|ONCE|ON}

The OFF and ONCE parameters have a similar effect. Auto Zero OFF or Auto Gain OFF doesn't issue a new offset measurement. However, Auto Zero ONCE or Auto Gain ONCE issues an immediate offset measurement.

4.1.2 Filter

Filter is used to remove noises in measurement readings. M3500A is equipped with two types of filters: AC filter and digital filter. AC filter is for AC measurements only. It also affects the speed of the multimeter to yield a measurement reading. Digital filter further stabilizes the measurement readings by averaging. Both of them are described in detail in the subsequent sections respectively.

4.1.2.1 AC Filter

Definition:

User is allowed to set the bandwidth for selecting one of the three AC filters (Slow, Medium and Fast), in order to achieve either higher accuracy in low frequency measurements or faster AC settling time.

Defaults

The factory default is 20 Hz (Medium). Users can select their filter type as they wish when setting bandwidth value. The selection is stored in a volatile memory and the default setting will be restored when the meter is power-off.

<i>Bandwidth</i>	<i>AC Filter</i>	<i>Time</i> <i>(seconds per reading)</i>
3 Hz ~ 300 Hz	Slow	7
20 Hz ~ 300 Hz	Medium	1
200Hz ~ 300 Hz	Fast	0.1

Table 4-2

How to set AC Filter in AC measurements:

User can set the AC Filter either through the front panel operation or through the remote interface operation.

Front Panel Operation

Press CONFIG + ACV button. Use \leftarrow and \rightarrow buttons to locate "BAND WIDTH" submenu, and then press ENTER to select it. Look for the desired bandwidth using \leftarrow and \rightarrow buttons. Then press ENTER on your selection. There are three options: 3Hz, 20Hz and 200Hz. The locations of these buttons are shown with red rectangle frames in **Figure 4-2**.

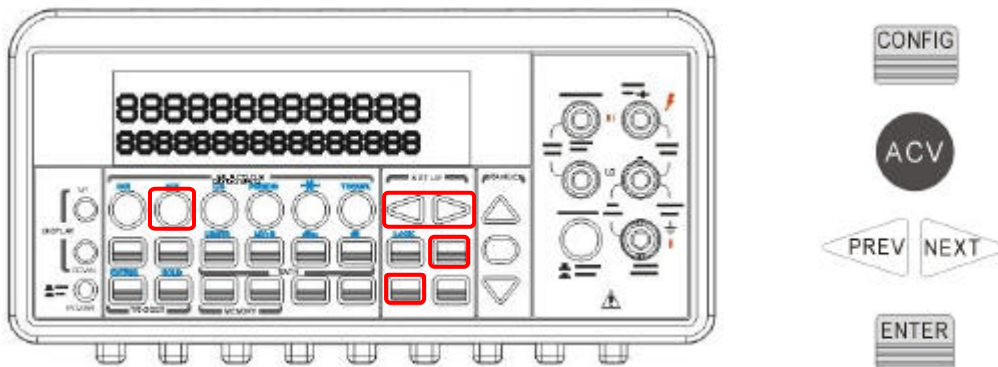

Figure 4-2

Remote Interface Operation

From your PC terminal, use the following command to specify the filter type:

```
DETECTOR:BANDwidth { 3 | 20 | 200 | MIN | MAX }
```

4.1.2.2 Digital Filter

Definition:

M3500A uses an averaging digital filter to yield a reading for display from a specified number of measurement readings in the past. The past measurement readings are stored in a stack of memory. The number may be in the range of 2 to 100. User may select one of the two modes of digital filter operations: Moving Average and Repeating Average.

The moving average filter puts the specified number of reading conversions in a first-in, first-out order. The very first measurement reading simply fills up the stack. To yield a reading for display, the filter produces an average of the stacked measurement readings every time a new measurement reading is available and replaces the oldest reading in

the stack. In the repeating average mode, the multimeter waits for the measurement reading stack to fill up and then take an average to produce a reading for display. It then flushes the stack and starts over with an empty stack. Consequently, the repeating digital filter yields one reading for display every specified number of measurement readings.

Digital filter is not available for diode, continuity, frequency and period measurements.

Default

The digital filter is enabled and is in moving average mode with 10 readings by default.

How to enable/disable digital filter

Press FILTER button to switch the digital filter function. The "FILT" annunciator indicates the state of the digital filter. When it is lit, the filter is enabled.

How to configure digital filter:

You can configure the digital Filter either through the front panel operation or through the remote interface operation.

Front Panel Operation

For READINGS setting, please press CONFIG and then FILTER button for selecting READINGS. Press ENTER to access. Use `?`, `?`, `?` and `?` buttons to set the READINGS (from 2 to 100) in order to get an average value. Press ENTER when it's ready.

For MODE setting, please press CONFIG and then FILTER button for selecting MODE. Press ENTER to access. Use `?`, `?` to select MOVING AVG. or REPEAT AVG.. Please ENTER to confirm.

Press FILTER button to enable or disable this function.

Remote Interface Operation

Use the following commands to set your digital filter:

SENSe:AVERage:TCONtrol {MOVing|REPeat}

SENSe:AVERage:TCONtrol?

SENSe:AVERAge:COUnT { <value> | MI Nimum | MAXimum }
SENSe:AVERAge:COUnT? [MI Nimum | MAXimum]
SENSe:AVERAge:STATe { OFF | ON }
SENSe:AVERAge:STATe?

4.1.3 Resolution Setting (Digits)

Definition

Resolution is the number of digits a multimeter can measure. User can select the resolution for a specific measurement. The choices for the resolution setting are: fast 4 ½, slow 4 ½, fast 5 ½, slow 5 ½, fast 6 ½ and slow 6 ½. For a higher accuracy, user can select 6 ½ digit resolution. For a faster measurement, user can select 4 ½ digit resolution.

The resolution setting applies to all math operations under the selected measurement function. The selected value is stored in a volatile memory and the setting is only valid for the current measurement function. User can select different resolution for different measurement function.

Default

The default value for the resolution is slow 5 ½ digit and the default value will be restored when the meter has been turned off or after a remote interface reset. The user selected value for the resolution setting is stored in a volatile memory and the setting is only valid for the current measurement function. Please refer to **Table 2-1** on page 24.

? **Note:** The resolution setting for AC measurements is actually fixed at 6 ½ digits. When user selects a lower resolution, the meter will mask out the extra digits. User's selection of resolution for AC function will not affect the actual speed or accuracy.

How to set the resolution

The resolution can be set either through the front panel or the remote interface operation.

Front Panel Operation

There are two ways to set the resolution. The locations of the buttons are shown with red rectangle frames in **Figure 4-3**.

A.

- First select your desired measurement function by pressing one of the function buttons located on the first row of your meter's front panel.
- Press DIGITS button to select your desired resolution for your measurement. User can press DIGITS button several times to see how the resolution setting changes from 4 ½, 5 ½ to 6 ½.

? Note: When using Method A to set the resolution, your options are 4 ½ (slow), 5 ½ (slow) and 6 ½ (fast).

B.

- Press CONFIG and then select a function as you wish from DCV, DCI (SHIFT + DCV), O2, O4 (SHIFT + O2), FREQ and PERIOD (SHIFT + FREQ).
- Press ENTER on RESOLUTION submenu. If it is not shown on the display, use ? and ? to locate it.
- Use ? and ? to find your desired resolution. Press ENTER on your choice.

? Note: The resolution of AC measurements is fixed at 6 ½ digit.

? Note: The options for frequency and period measurements are 4 ½ (slow), 5 ½ (slow) and 6 ½ (slow).

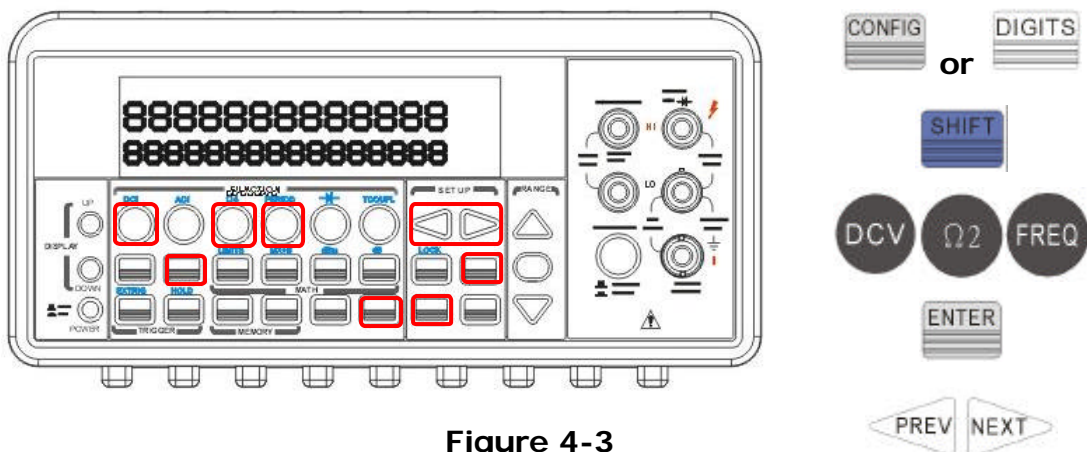

Figure 4-3

Remote Interface Operation

Use the following commands on your PC terminal to set the resolution for your measurement.

CONFigure:<function> <range>,<resolution>

MEASure:<function>? <range>,<resolution>

SENSe:<function>:RESolution <resolution>

4.1.4 DC Input Resistance

Definition

To reduce the effect of loading errors due to the input resistance, M3500A allows user to select a much larger input resistance (> 10G Ω) for low input DC voltage (100mV, 1V and 10V) measurements. This feature is only available for DC voltage measurements and it is not applicable to other measurement functions.

Default

The default input resistance for all measurements is 10M Ω . Please refer to **Table 2-1** on page 24. The DC input resistance can only be changed for measurements with 100mV, 1V or 10V range. For 100V DCV, 1000 V DCV and other measurement functions, the input resistance is fixed at 10M Ω and can not be changed. Also note that the user selected value is stored in a volatile memory. The default setting will be restored after the meter has been turned off.

How to set the DC input resistance

You can set the DC input resistance either through the front panel operation or through the remote interface operation.

Front Panel Operation

Press CONFIG + DCV , and then use ? and ? buttons to locate "INPUT R" option. Press ENTER to select it. Then select desired value for the input resistance by pressing ? or ? button. Press ENTER to choose it. Two values are available: 10M Ω or > 10G Ω . The locations of these buttons are shown with red rectangle frames in **Figure 4-4**.

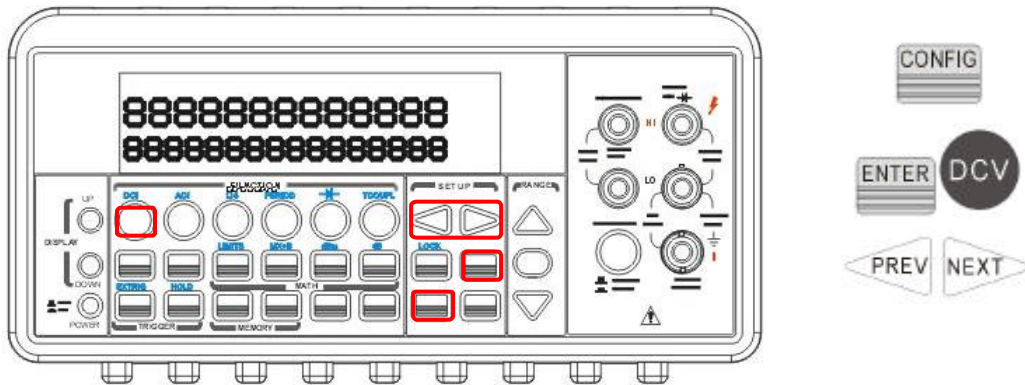

Figure 4-4

Remote Interface Operation

The automatic input resistance mode can be enabled / disabled. With AUTO OFF (default), the input resistance is fixed at 10MO for all ranges. With AUTO ON, the input resistance is set to >10GO for the three lowest DC voltage ranges (100mV, 1V and 10V). Use the following command from your PC terminal to disable the auto input DC resistance setting (the result is a fixed input DC resistance at 10M O for all measurements.)

`INPut:IMPedance:AUTO {OFF | ON}`

4.1.5 Threshold Resistance (Continuity)

Definition

When testing continuity, the beeper goes off when the measured resistance is less than the threshold resistance. The threshold resistance can be set to any value between 10 and 10000.

Default

The factory default for continuity threshold resistance is 100. User's selection is stored in a volatile memory and the default value will be restored after the meter has been turned off.

How to set the threshold resistance

User can change the threshold resistance only through the front panel. Press CONFIG button and then CONT button. Use \leftarrow and \rightarrow buttons to move through the digits and lower or increase the number to your desired value using \downarrow and \uparrow buttons, then press ENTER button to set the value. The locations of these buttons are shown with red rectangle frames in **Figure 4-5**.

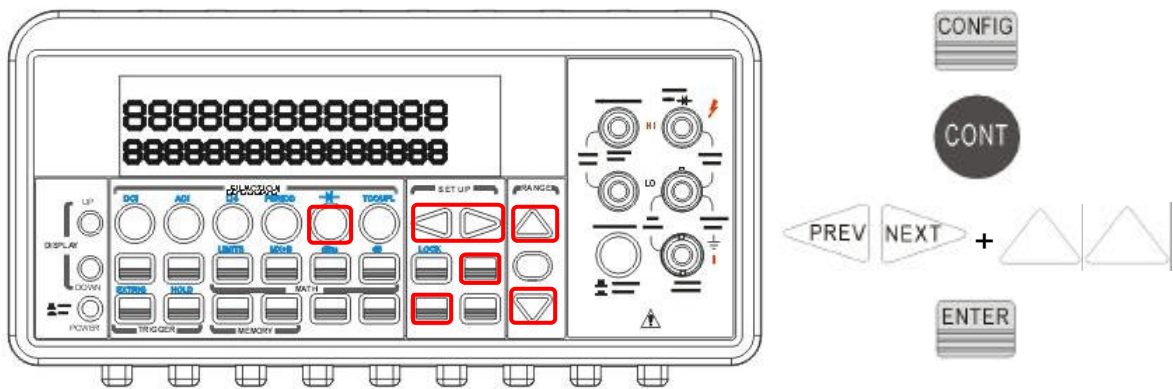

Figure 4-5

4.1.6 Range (Manual and Auto)

Definition

When making measurements except CONT, DIODE and Temperature, you can let the machine choose ranges for you, or you can select the appropriate ranges manually by yourself. The difference between auto-range and manual-range is the settling time. Auto-range is a convenient way for user, but manual-range can usually speed up the process.

If the input signal is beyond allowed range, an "OVLD" message will be shown on the display. The threshold of maximum/minimum readings for each range are 120 % of the range for maximum and 10% of the range for minimum.

Default

The default is auto-range. The user selected range is stored in volatile memory and the default will be restored when the meter is power-off. Please refer to **Table 2-1** on page 24 for the factory default range.

How to set the auto / manual range:

You can set the auto / manual range either through the front panel operation or through the remote interface operation.

Front Panel Operation

First choose a measurement function on the front panel, then press "AUTO" button to select auto-range feature. Or use \uparrow and \downarrow buttons to manually select a range. If selected range is not shown on the bottom of the display, press round PREV or NEXT buttons until the range information appears. The locations of these buttons are shown with a red rectangle frame in **Figure 4-6**.

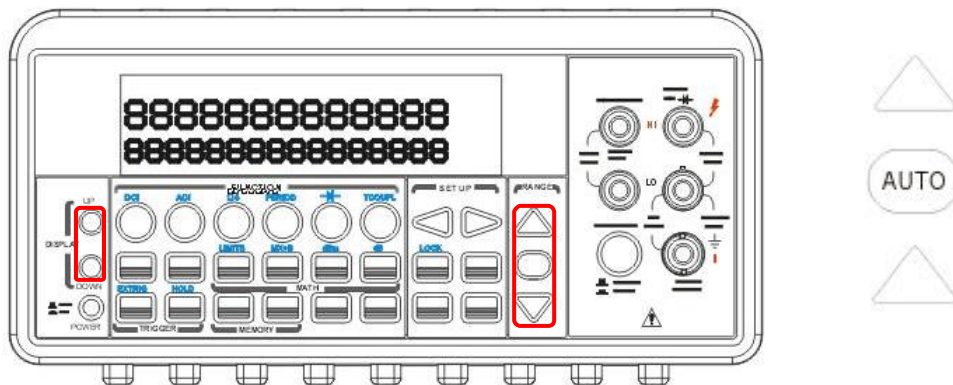

Figure 4-6

Remote Interface Operation

Use the following commands from your PC terminal to set the range:

CONFigure:<function> <range>,<resolution>

MEASure:<function>? <range>,<resolution>

SENSe:<function>:RANGe <range>

SENSe:<function>:RANGe:AUTO {OFF|ON}

4.1.7 Rate (Integration Time)

Definition

Integration time is the period of time the analog-to-digital (A/D) converter takes to sample the input signal. The integration time feature allows user to optimize either the speed or the resolution, as well as the noise rejection and the accuracy of the measurement. The unit of the integration time is in PLC (power line cycles). One PLC for 60 Hz is 16.67 ms, and for 50 Hz is 20 ms.

There are 4 different integration times in M3500A for user to select from: 0.02, 0.1, 1 and 10 PLCs.

Default

For DCV, DCI, and resistance measurement, the default integration time is 1 PLC. The user selected value is stored in a volatile memory and the default value will be restored when the meter is power-off.

How to set the integration time:

You can set the integration time either through the front panel operation or through the remote interface operation.

Front Panel Operation

Integration time is set indirectly when user selects the measurement resolution. Please refer to chapter 4.1.3 for details about how to set resolution or the digits. **Table 4-1** on page 51 shows the relationship between the resolution and the integration time.

Remote Interface Operation

Use the following commands on your PC terminal to set the resolution.

CONFigure:< function> <range>, <resolution>

MEASure:< function>? <range>, <resolution>

SENSe:< function>:RESolution <resolution>

Or you can set integration time directly by the following commands.

SENSe:VOLTage:DC:NPLCycles {0.02|0.1|1|10|MINimum|MAXimum}
SENSe:VOLTage:DC:NPLCycles? [MINimum|MAXimum]
SENSe:CURRent:DC:NPLCycles {0.02|0.1|1|10|MINimum|MAXimum}
SENSe:CURRent:DC:NPLCycles? [MINimum|MAXimum]
SENSe:RESistance:NPLCycles {0.02|0.1|1|10|MINimum|MAXimum}
SENSe:RESistance:NPLCycles? [MINimum|MAXimum]
SENSe:FRESistance:DC:NPLCycles {0.02|0.1|1|10|MINimum|MAXimum}
SENSe:FRESistance:DC:NPLCycles? [MINimum|MAXimum]

For frequency and period measurements, aperture time (or gate time) is analogous to integration time, and you can use the following commands to set it. Specify 10 ms (4 1/2 digits), 100 ms (default; 5 1/2 digits), or 1 second (6 1/2 digits).

SENSe:FREQuency:APERture {0.01|0.1|1|MINimum|MAXimum}
SENSe:FREQuency:APERture? [MINimum|MAXimum]
SENSe:PERiod:APERture {0.01|0.1|1|MINimum|MAXimum}
SENSe:PERiod:APERture? [MINimum|MAXimum]

4.1.8 Sensor Selection for Temperature

Measurements

The multimeter supports both thermocouple and RTD. User needs to configure the multimeter for the right sensor type before they can make temperature measurements.

RTD

Definition

If you are using RTD, the options are: PT100, D100, F100, PT385, PT3916, user-defined RTD, NTCT and SPRTD. If you need to change the factors that are used to calculate the temperature in RTD, choose user-defined RTD in which you are able to change any factors as you wish. The default factors used are listed in **Table 4-3**:

Type	Alpha	Beta	Delta	R-zero
PT100	0.003850	0.10863	1.49990	100?
D100	0.003920	0.10630	1.49710	100?
F100	0.003900	0.11000	1.49589	100?
PT385	0.003850	0.11100	1.50700	100?
PT3916	0.003916	0.11600	1.50594	100?
NTCT	0.003850	0.10863	1.49990	100?

Table 4-3

Here is the temperature equation that is used to determine the RTD temperature:

When $t < 0^{\circ}\text{C}$:

$$R_t = R_0 \left[1 + At + Bt^2 + Ct^3(t - 100) \right]$$

When $0^{\circ}\text{C} < t < 630^{\circ}\text{C}$:

$$R_t = R_0 \left(1 + At + Bt^2 \right)$$

Where:

$$A = a \left(1 + \frac{d}{100} \right)$$

$$B = -ad \cdot 10^{-4}$$

$$C = -ab \cdot 10^{-8}$$

If you are using SPRTD(Standard Platinum RTD), select SPRTD and specify the seven coefficients under SPRTD submenu.

The ITS (International Temperature Scale) -90 standard provides two reference equations for Standard Platinum Thermometers covering temperature range from 18.8033K to 1234.93K. However, one SPRTD usually cannot cover the entire range, so the temperature range is broken up into a few subranges. These subranges depend on the

calibration point of temperature scale and are based on the melting or triple points of various pure substances. For an exact list of the elements needed and details on RTD calibration, refer to NIST Technical Note 1265 "Guidelines For Realizing the International Temperature Scale of 1990". In each subrange, the calibration constants required for that subrange are listed.

Default

The default sensor type in M3500A is PT100.

How to set up RTD

You can set up the RTD configuration either through the front panel operation or through the remote interface operation.

Front Panel Operation

If you are using RTD, press CONFIG and then TEMP. Use \leftarrow and \rightarrow to locate SENSOR submenu. Press ENTER to go to the submenu. Use \leftarrow and \rightarrow to locate your sensor type Press ENTER to select your desired sensor type.

Choosing **USER** takes you to a menu where you can specify factors used in the calculation equation to obtain the temperature. Use \leftarrow and \rightarrow to move through the digits and \leftarrow and \rightarrow to change the numbers to a desired value. Press ENTER to set the value.

Choosing **SPRTD** takes you to a menu where you can specify the seven coefficients that are used to determine the temperature. Use \leftarrow and \rightarrow to move through the digits and \leftarrow and \rightarrow to change the numbers to a desired value. Press ENTER to set the value.

Remote Interface Operation

Use the following commands to set up the RTD configuration.

```
SENSe:TEMPerature:RTD:TYPE{PT100|D100|F100|PT385|PT3916|USER|SPRTD|NTCT}
```

```
SENSe:UNIT {Cel|Far|K}
```

```
SENSe:UNIT?
```

```
SENSe:TEMPerature:RTD:RZERo { <value> |MINimum|MAXimum}
```

```
SENSe:TEMPerature:RTD:ALPHA { <value> |MINimum|MAXimum}
```

```
SENSe:TEMPerature:RTD:BETA { <value> |MINimum|MAXimum}
```

SENSe:TEMPerature:RTD:DELTA { <value> | MI Nimum | MAXimum }
SENSe:TEMPerature:SPRTD:RZERo { <value> | MI Nimum | MAXimum }
SENSe:TEMPerature:SPRTD:A4 { <value> | MI Nimum | MAXimum }
SENSe:TEMPerature:SPRTD:B4 { <value> | MI Nimum | MAXimum }
SENSe:TEMPerature:SPRTD:AX { <value> | MI Nimum | MAXimum }
SENSe:TEMPerature:SPRTD:BX { <value> | MI Nimum | MAXimum }
SENSe:TEMPerature:SPRTD:CX { <value> | MI Nimum | MAXimum }
SENSe:TEMPerature:SPRTD:DX { <value> | MI Nimum | MAXimum }

Thermocouple

Definition

If you are using the thermocouple, the options are: type E, J, K, N, R, S and T. After selecting your thermocouple type, you need to configure the reference junction also. Typically, each thermocouple card uses one reference junction. If the junction type is simulated, the defined simulated junction temperature is used. If the junction type is real, you need to close that channel from the scanner card before acquiring the temperature. Also you must enter an offset voltage for the selected reference junction.

How to set up thermocouple

You can set up the thermocouple configuration either through the front panel operation or through the remote interface operation.

Front Panel Operation

Press CONFIG and then SHIFT + TEMP to go to the thermocouple configuration menu. Use ? and ? to locate "TYPE" submenu, press ENTER to select it. Then again use ? and ? to locate the right thermocouple type for you, press ENTER on your selection.

To configure the reference junction, use the same step to go to the thermocouple configuration submenu. Use ? and ? to locate "RJUNCTION" submenu, and then press ENTER. The options are "SIMULATED" and "REAL". Selecting "SIMULATED" allows you to set a specific value to be a default temperature. Selecting "REAL" allows you to set an offset voltage. Use ? and ? to move through the digits and ? and ? to change the numbers to a desired value. Press ENTER to input a

specific value.

Remote Interface Operation

Use the following commands to set up the thermocouple configuration.

SENSe:UNIT {Cel|Far|K}

SENSe:UNIT?

SENSe:TCouple:TYPE {E|J|K|N|R|S|T}

SENSe:TCouple:RJUNcion:RSElect {REAL|SIMulated}

SENSe:TCouple:RJUNcion:SIMulated { <value> |MINimum |MAXimum }

SENSe:TCouple:RJUNcion:REAL:OFFSet { <value> |MINimum |MAXimum }

4.1.9 Remote Interface Selection

The multimeter supports both GPIB and USB interfaces, but only one interface can be activated at a time. If you are using GPIB, you must set the address for the multimeter. You can set the address to any value from 0 and 31. The address is set to "11" when the multimeter is shipped from the factory.

? **Note:** The remote interface can only be set through the front panel operations.

How to select a remote interface

Press MENU and then use ? and ? to select INTERFACE. Then Press ENTER on your choice of USB or GPIB interface.

How to set address when using GPIB

Press MENU and then use ? and ? to access INTERFACE. Select GPIB to set address. Use ? , ? , ? and ? to adjust the numbers to the desired address. Press ENTER to set it.

4.1.10 Input Terminal Switch

Definition

User can select either the front input terminals or the rear input terminals for their measurements. There are 5 input terminals in the front panel as well as the rear panel. If the rear terminal is enabled the REAR annunciator at the upper side will be shown.

Default

The default situation is the front terminals.

How to switch the terminals:

To switch between the front and the rear input terminals, press "TERMINALS" switch button on the front panel. Please see the following figure for the location of the switch. The location of the button and terminals is shown with a red rectangle frame in **Figure 4-7**.

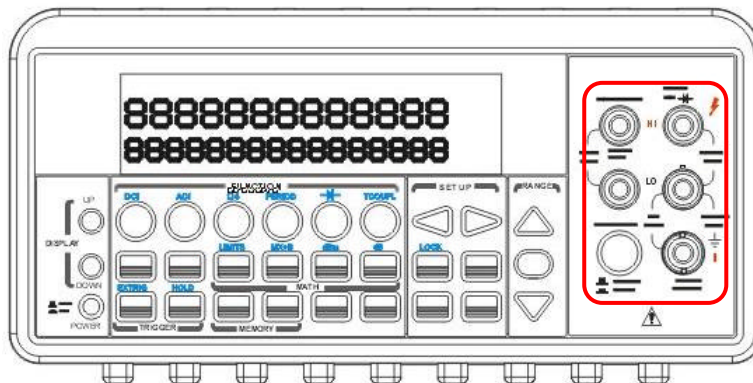
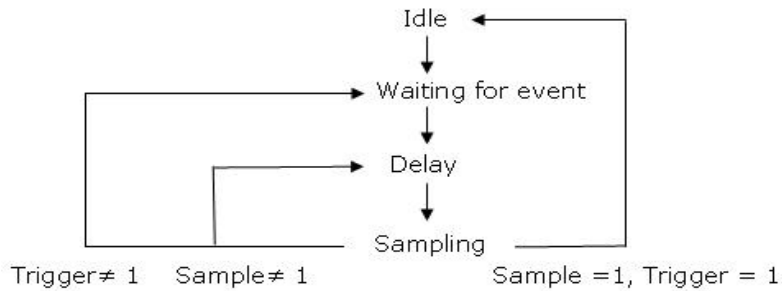

Figure 4-7

4.2 Trigger Operations

In this section we will discuss the triggering system in M3500A. M3500A provides a variety of trigger operations for user. User can select a trigger mode, a trigger source and different trigger settings for a specific measurement. The user's selection is stored in a volatile memory and the

default settings will be restored after power-off. **Figure 4-8** shows the trigger operation in M3500A.



Trigger Operation Flow Chart

Figure 4-8

4.2.1 Trigger Mode

There are three trigger modes in M3500A: auto, immediate, and single triggering. User can specify the trigger mode for their measurement. The factory default is auto triggering when the meter is power-on.

A. Auto Triggering Mode (Front Panel Operation only)

Definition

Auto triggering takes continuous readings at a fastest rate possible for the present measurement. The rate of taking readings depends on the current settings. This function is only available through the front panel. The auto triggering is also the default for trigger mode in M3500A.

How to use Auto Trigger

Press ATUO TRIGGER on the front panel to toggle for enabling auto trigger mode. The location of the button is shown with a red rectangle frame on **Figure 4-9**.

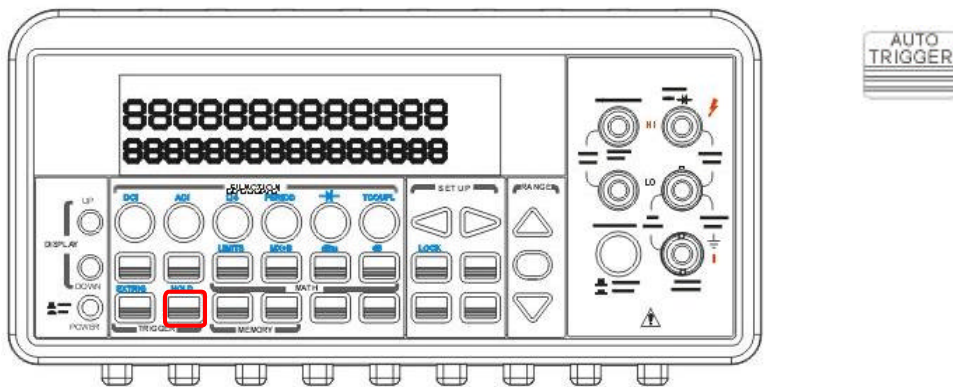

Figure 4-9

B. Internal Immediate Trigger Mode (Remote Interface Operation Only)

Definition

The immediate triggering mode is only available through the remote interface operations and it is the default for the remote interface operations. When the meter is in immediate trigger mode, a trigger will be issued immediately as soon as the meter is in “wait for event” state.

How to use Immediate Trigger

Use the following command in your PC terminal to set the internal immediate trigger.

TRIGger:SOURce IMMEDIATE

C. Single Trigger Mode (accessible only through the front panel)

Definition

Single trigger mode takes one reading (or specified number of readings) each time when user presses SINGLE key. (Please refer to 4.2.3 for setting the number of samples on each trigger.) When the TRIG annunciator on the display is lit, the meter is ready for next trigger event. The single trigger mode is only available through the front panel operations.

How to use Single Trigger

First select the measurement function, and then press SINGLE key on

the front panel to set the trigger mode. The location of the button is shown with a red rectangle frame in **Figure 4-10**.

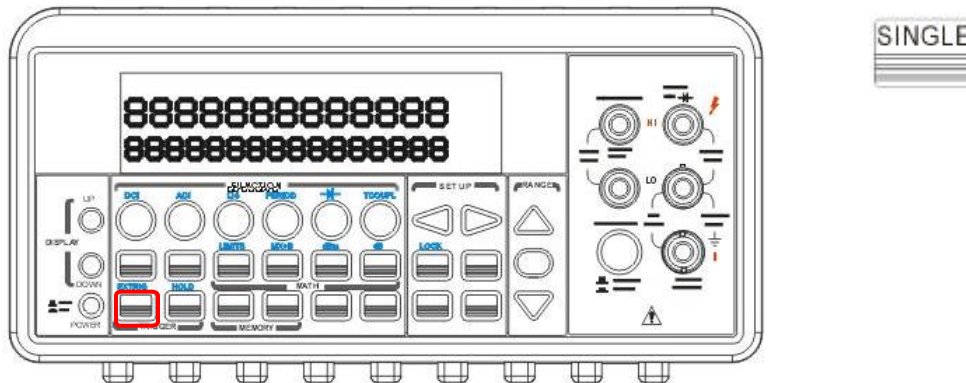

Figure 4-10

4.2.2 Trigger Source

In M3500A, user can specify the trigger source to be one of these three options: front panel operations, external hardware trigger source and remote interface operations.

Front Panel Operation

Use the front panel buttons - AUTO TRIGGER for auto triggering and SINGLE for single triggering.

External Hardware

User applies a trigger pulse to the Ext TRIG (BNC) terminal on the rear panel. External hardware triggering is like using single trigger but the trigger source is an external hardware. When the multimeter receives a pulse from the trigger source, it takes one reading, or a specified number of readings. To set the external hardware trigger, press both the SHIFT + SINGLE buttons to enable external hardware trigger. The lit "EXT" annunciator on the display indicates the enabling of the external hardware trigger.

Remote Interface Operation (By software or internal trigger)

By software trigger: The software trigger is similar to the single

triggering, but instead of using the "SINGLE" button on the front panel, you send a command from your PC to the multimeter to generate an event. For using software trigger, use the following command from your PC terminal to set trigger source:

TRIGger:SOURce BUS

By internal trigger: The internal trigger is the default trigger mode for the Remote Interface Operation. In the internal trigger mode, a trigger signal will be issued whenever the multimeter is in the wait-for-trigger state. To set the internal trigger, use the following command from your PC terminal:

TRIGger:SOURce IMMEDIATE

4.2.3 Trigger Setting

In M3500A, user can specify a variety of trigger settings including the number of samples per trigger, the number of triggers per event, reading hold, and the trigger delay for their measurements.

A. Number of samples on each trigger

By default, the multimeter takes only one reading on each trigger, but you can instruct the multimeter to take specific number (up to 50000) of readings each time it receives a trigger. The user's input setting is stored in a volatile memory which will be cleared after the meter has been turned off and the default value will be restored. You can set the number of samples on each trigger through front panel or the remote interface.

Front Panel Operation

Press MENU button and locate "TRIG" submenu by pressing ? and ? buttons. Press ENTER to choose "TRIG" option. Again locate "N SAMPLE" submenu using ? and ? buttons and then press ENTER to select it. Then set the desired number by pressing ? and ? buttons to increase or decrease the number, and using ? and ? buttons to move through the digits. The locations of these buttons are shown with red rectangle

frames in **Figure 4-11**.

Procedures: MENU ? TRIG ? N SAMPLE ? <Number>

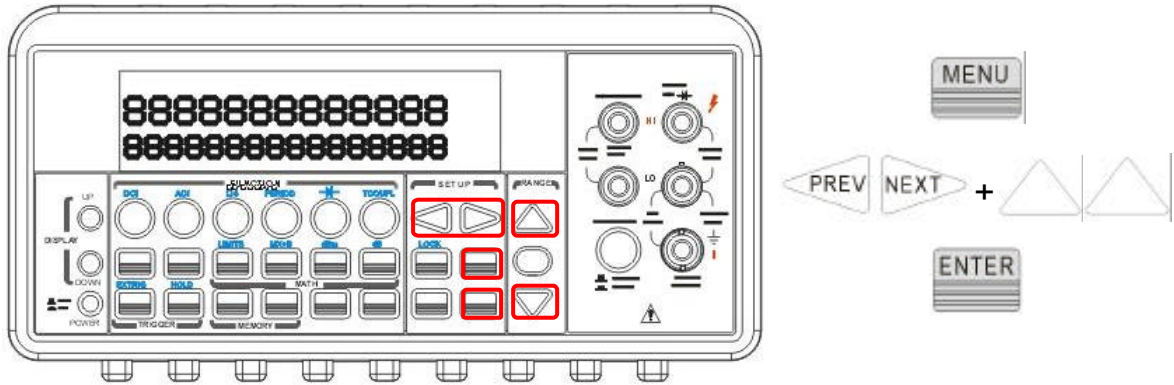

Figure 4-11

Remote Interface Operation

Use the following command to set the number of samples from your PC terminal.

SAMPlE:COUNT <value>

B. Number of triggers

Although the meter normally takes one trigger before returning to the "idle" state, user can manually specify the number of triggers it accepts before the "idle" state. However, this can only be done through the remote interface. The following command show how to set multiple triggers per returning idle state.

TRIGger:COUNT <value>

C. Reading hold

The reading hold feature is used to hold a stable reading on the display. When a reading is stable, enabling the reading hold will hold the stable reading and trigger a beeping sound. Reading hold feature depends on an adjustable sensitivity band to determine if a reading is stable. The multimeter considers a reading stable when three consecutive readings

are within the sensitivity band. Chapter 4.4.6 will explain how to adjust the sensitivity band.

How to use reading hold

This feature is only available from the front panel operations. To enable reading hold, press both SHIFT and AUTO TRIGGER buttons. To disable it, simply press AUTO TRIGGER. The locations of the buttons are shown with red rectangle frames in **Figure 4-12**.

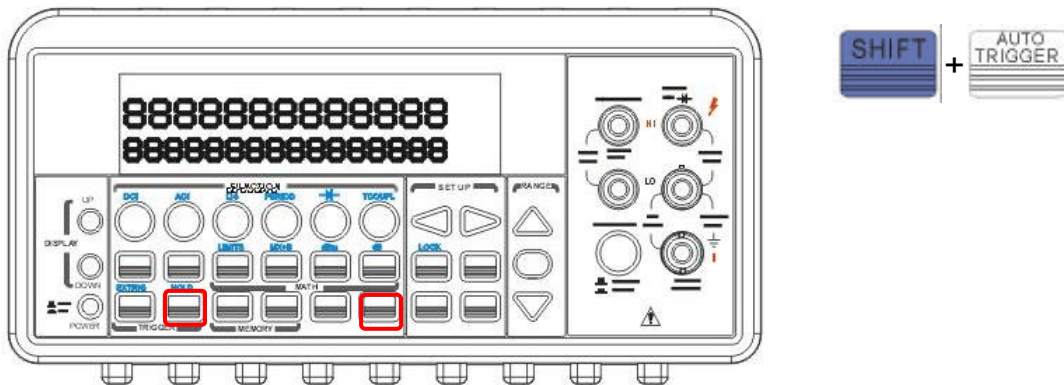

Figure 4-12

D. Trigger delay

This feature is useful for user who needs a longer delay time to wait for the system to be stabilized. The time needed to stabilize a measurement system is called the “settling time.” The settling time depends on the measurement range, cable properties and signal source.

Defaults

The default of the trigger delay is automatic. M3500A automatically selects a delay time for you according to the setting of the measurement if you do not specify a delay. A list of the default for each measurement function is shown on **Table 4-4**. The range for the delay is from 0 to 3600 seconds. User's selection of delay time is stored in a volatile memory and the default will be restored when the meter is power-off.

The internal settings of automatic trigger delay

The delay time for automatic trigger delay is determined by the selection

of measurement function, range, and the setting of integration time and AC filter speed. **The following table shows the default delay time for each measurement setting.**

Measurement Function	Setting	Trigger Delay Time
DCV/DCI	PLC \geq 1	1.5 ms
	PLC < 1	1.0 ms
O2 and O4 (PLC \geq 1)	1000 ~ 100k Ω	1.5 ms
	1 M Ω	15 ms
	10 M Ω ~ 100 M Ω	100 ms
O2 and O4 (PLC < 1)	1000 ~ 100k Ω	1.0 ms
	1 M Ω	10 ms
	10 M Ω ~ 100 M Ω	100 ms
ACV/ACI (Remote Interface/ External Trigger/ Single Trigger)	3 Hz	7.0 s
	20 Hz	1.0 s
	200 Hz	600 ms
ACV/ACI (Front Panel w/ Auto Trigger On)	3 Hz	1.5 s
	20 Hz	200 ms
	200 Hz	100 ms
Frequency/Period	Remote Interface / External	1.0 s
	Front Panel w/ Auto Trigger ON	0 s

Table 4-4

How to specify a delay time

User can set the delay time from either the front panel operations or the

remote interface operations.

Front Panel Operation

To set the delay time, press MENU button and use \leftarrow and \rightarrow buttons to locate "TRIG" option. Press ENTER to select it. Then again find "DELAY" option using \leftarrow and \rightarrow buttons. Press ENTER to select it. Then use \leftarrow and \rightarrow buttons to move through the digits and \uparrow and \downarrow buttons to set the desired delay time (between 0 to 3600 second). The locations of the buttons are shown with red rectangle frames in **Figure 4-13**.

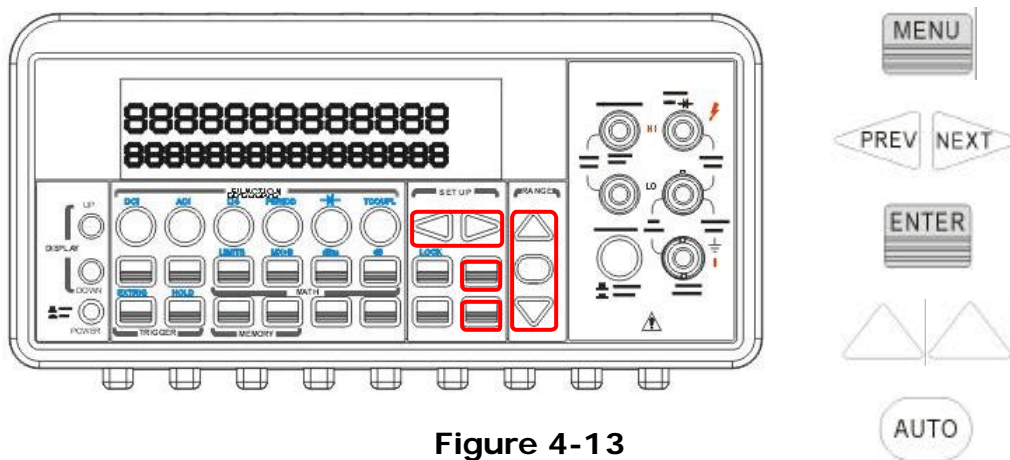

Figure 4-13

Remote Interface Operation

You can also use the remote interface operations from your PC terminal to set the trigger delay. To select a delay time, use the following command or set the trigger delay to be automatic:

TRIGger:DELay { <seconds> | MINimum | MAXimum }

or

TRIGger:DELay:AUTO { OFF | ON }

4.3 Math Operations

This section will introduce the mathematical operations in M3500A. There are eight math operations: RATIO, %, Min/Max, NULL, Limits, MX+B, dB and dBm testing. They either store data for later use or perform mathematical operations on the readings. Note that these math operations are available to all measurement functions except continuity and diode testing.

? Note: The "MATH" annunciator on the display indicates the state of a mathematical feature, excluding Ratio, and will be lit by enabling whichever math feature. Also, press the same buttons again for the enabled math feature will disable the same math feature.

? Note: Press RATIO button, the "RATIO" annunciator will be lit on the display.

4.3.1 Ratio

This function calculates the ratio of an input DC voltage to a reference DC voltage according to the following equation:

$$\text{Ratio} = \frac{\text{DC Input Voltage}}{\text{DC Reference Voltage}}$$

? Note: At the Sense terminals, the status must be in dc voltage measurement function and has a maximum measurable input of ± 12 Vdc. Autoranging is selected automatically for reference voltage measurements on the Sense terminals.

? Note: It is necessary to have a common reference to the Input LO and Sense LO terminals, and the voltage difference can not be greater than ± 2 volts.

? Note: The specified measurement range is used only to the signal

connected to the Input terminals. The signal on the Input terminals is allowed to be any dc voltage up to 1000 volts.

How to make a ratio measurement

There are two ways to make a ratio measurement: Through the front panel operation or through the remote interface operation.

Front Panel Operation

Use TERMINALS button to select the front terminals or the rear terminals. Press CONFIG + RATIO, and then use \leftarrow and \rightarrow buttons to locate "RESOLUTION" option (Refer to 4.1.3) and "FILTER" option (Refer to 4.1.2.2). Press ENTER to make choices. Then select desired value for it by pressing \leftarrow , \rightarrow , \uparrow and \downarrow button. Press ENTER to choose it. For operating this function, please press RATIO button and observe the reading on the display as shown as **Figure 4-14**.

? Note: To close this function, please press one of the measurement function buttons.

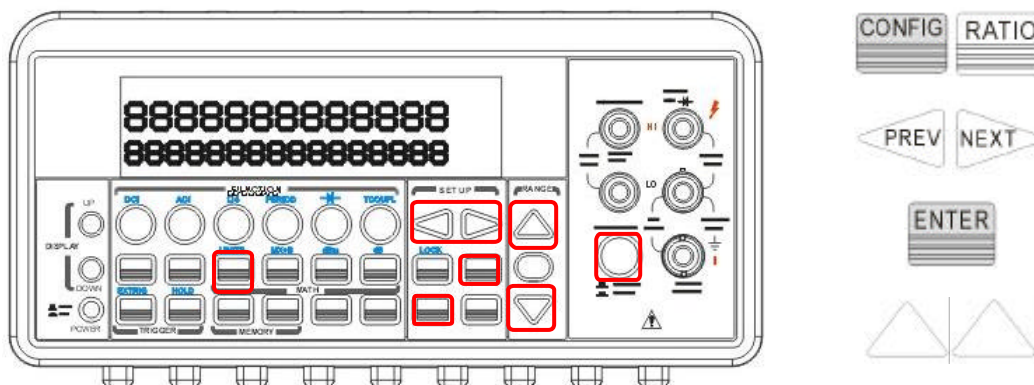

Figure 4-14

Remote Interface Operation

Use the following command to make a RATIO measurement.

CONFigure:VOLTage:DC:RATio{ <range>|MIN|MAX|DEF},{ <resolution>|MIN|MAX|DEF}

4.3.2 % (Percent)

Definition

This mathematical function calculates the ratio of a measurement reading to a specified target value as the form of percentage. The calculation formula is shown below:

$$\text{Percent} = \frac{\text{Input Reading}}{\text{Target Value}} \cdot 100$$

The specified target value is store in a volatile memory and will be cleared after the meter has been turned off or a remote interface reset.

How to use % (Percent) function

There are two ways to make a percent measurement: Through the front panel operation or through the remote interface operation.

Front Panel Operation

To specify a target value, user needs to configure Percent function by pressing CONFIG + %, then use \leftarrow and \rightarrow to move through the digits and \uparrow and \downarrow buttons to increase or decrease the numbers to a desired target value. Press ENTER to set the value. Press % to activate this function. And then observe the calculated percent value on the display as shown as **Figure 4-15**.

? **Note: Press % again to disable this function. The "MATH" annunciator on the display indicates the state of a mathematical feature.**

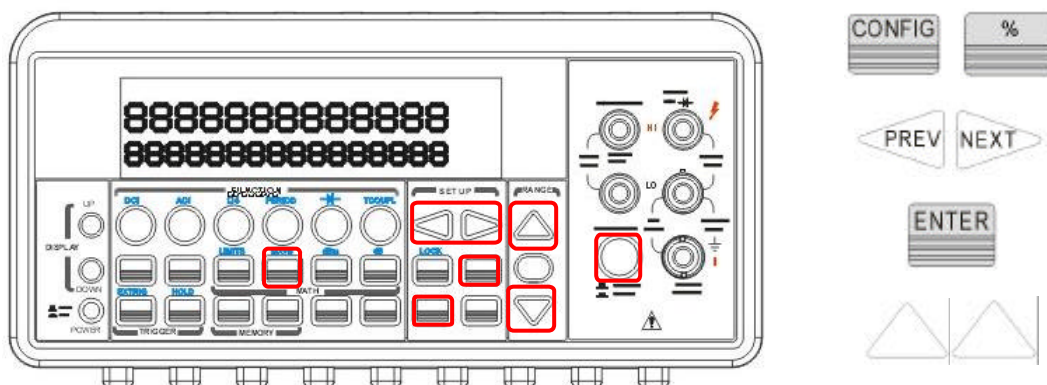

Figure 4-15

Remote Interface Operation

Use the following commands to enable and configure Percent function:

CALCulate:FUNCTION PERCent

CALCulate:STATe { OFF | ON }

CALCulate:STATe?

CALCulate:PERCent:TARGet { <value> | MI Nimum | MAXimum }

CALCulate:PERCent:TARGet? [MI Nimum | MAXimum]

4.3.3 Min/Max

Definition

When the Min/Max function is enabled, the multimeter takes in a series of readings from the measurements, stores the minimum and maximum readings in the memory, and then calculates the average value of all readings. The number of readings taken since Min/Max operation is enabled is recorded as well. These data are stored in a volatile memory and will be cleared when the meter is turned off, or when the MIN/MAX is turned on, or after a remote interface reset. The meter beeps every time when it captures a new minimum or maximum.

How to use Min/Max

You can use the Min/Max feature either through the front panel operation or the remote interface operation.

Front Panel Operation

User first selects the measurement function they wish to use, and then press MIN/MAX button to enable the Min/Max function. To read the min/max value, the average value or the readings count, user can press CONFIG button and then MIN/MAX button. Use ? and ? buttons to switch between those values. The locations of the buttons are shown with red rectangle frames in **Figure 4-16**.

? Note: Press MIN/MAX again to disable this feature. The "MATH" annunciator on the display indicates the state of a mathematical feature.

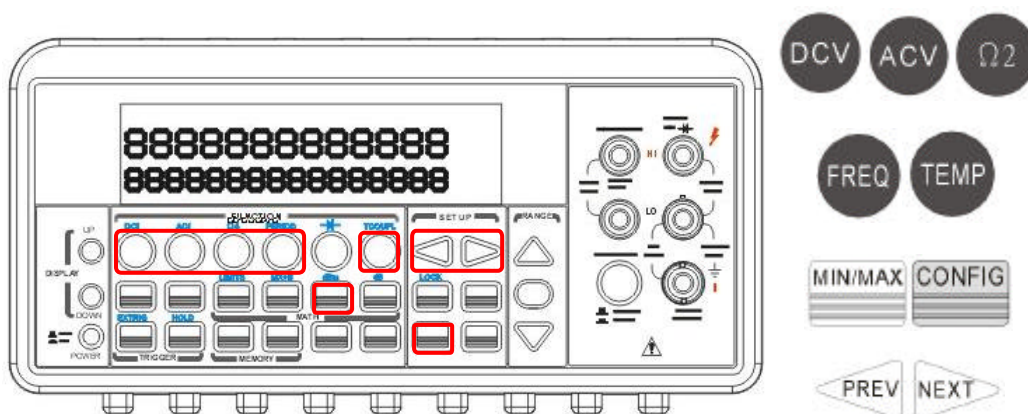

Figure 4-16

Remote Interface Operation

The following commands show you how to use the Min/Max operation from your PC terminal.

CALCulate:FUNCtion AVERAge

CALCulate:STATe {OFF|ON}

CALCulate:STATe?

CALCulate:AVERAge:MINimum?

CALCulate:AVERAge:MAXimum?

CALCulate:AVERAge:AVERAge?

CALCulate:AVERAge:COUNT?

4.3.4 Null

Definition

When null function is enabled, the displayed measurement reading is the difference between the measured input signal reading and the stored null (also called relative) value. The null (relative) value is stored in a volatile memory and the value will be cleared when the multimeter is power-off. Moreover, user can specify or alter a null value. The null feature is available for all functions, except continuity, diode. When user selects the null feature for a measurement, it is visible only for this measurement.

How to use null (relative) measurement

You can activate null feature from either the front panel operation or the remote interface operation.

The Front Panel Operation

The null measurements can be used with any function except continuity and diode. To store the null test lead resistance, short the two test leads together and then press NULL button. The new reading taken will replace the old value, if any, in the null register. Then, connect the two test leads to the input source. The value with null offset will show on the display. In addition, the null offset value can be adjusted manually by pressing CONFIG then NULL. Use \leftarrow and \rightarrow buttons to move through the digits and use \uparrow and \downarrow buttons to increase or decrease the numbers to a desired value. Press ENTER to set the value. The locations of the buttons are shown with red rectangle frames in **Figure 4-17**.

? Note: Press NULL again to disable this feature. The "MATH" annunciator on the display indicates the state of a mathematical feature.

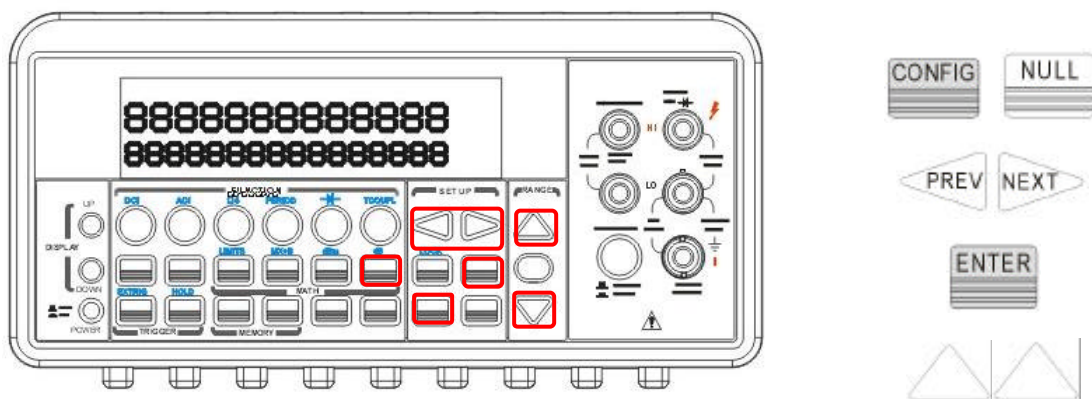

Figure 4-17

The Remote Interface Operation

You can use the following commands on your PC terminal to make a null measurement.

CALCulate:FUNCtion NULL

CALCulate:STATe {OFF|ON}

CALCulate:STATe?

CALCulate:NULL:OFFSet {<value>|MAXimum|MINimum}

4.3.5 Limits Test

The limits testing operation allows user to adjust a maximal and a minimal limit values. The multimeter beeps and an “HI” or “LO” message will be shown when the reading exceeds the upper or lower limit respectively. Users can specify the limit values and the values are stored in a volatile memory. The default values for both upper and lower limits are “0”. This function is available to all except continuity and diode measurements.

How to set the limits

You can set the limits or make a limit testing either through the front panel or the remote interface operation.

Front Panel Operation

To set the limits, user needs to configure the LIMITS math function by pressing CONFIG + SHIFT + RATIO, and then use ? and ? to locate either lower limit (MIN) or upper limit (MAX). Press ENTER to select the

limit you wish to set. Then use ? and ? to move through the digits and ? and ? to increase or decrease the numbers to a desired value. Press ENTER to set the value. The locations of the buttons are shown with red rectangle frames in **Figure 4-18**.

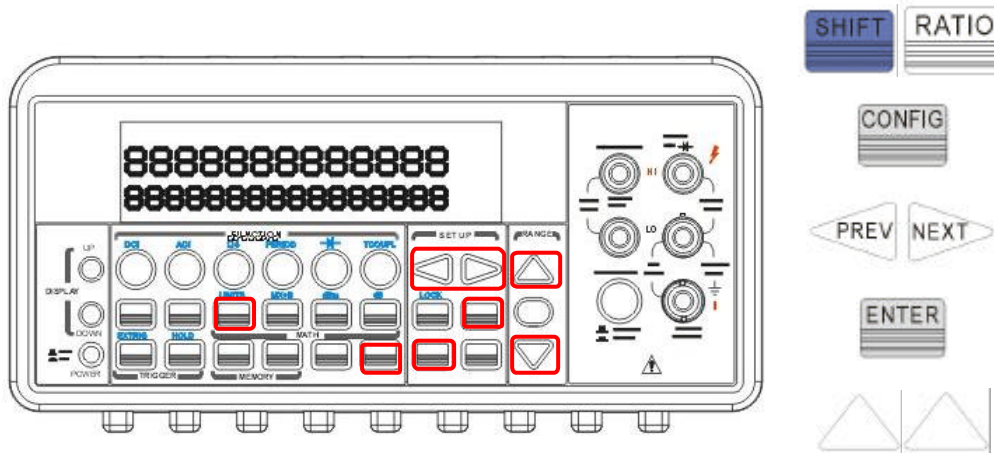

Figure 4-18

How to make a limit testing

The locations of the buttons are shown with red rectangle frames in **Figure 4-19**.

- Select a measurement function for purpose except continuity and diode.
- Enable the limit operation by pressing SHIFT + RATIO buttons.
- After enabling the limit function, user can set the limit value as mentioned above.
- Observe the displayed reading.

? Note: Press SHIFT+RATIO again to disable this feature. The "MATH" annunciator on the display indicates the state of a mathematical feature.

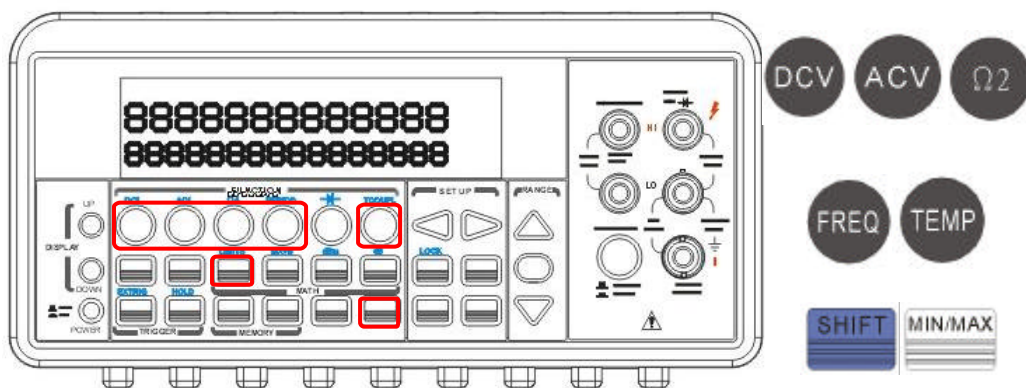

Figure 4-19

Remote Interface Operation

Use the following commands to enable the limits function or to set the limits:

CALCulate:FUNCtion LIMit

CALCulate:STATE {OFF|ON}

CALCulate:STATE?

CALCulate:LIMit:LOWer { <value> |MINimum|MAXimum}

CALCulate:LIMit:UPPer { <value> |MINimum|MAXimum}

4.3.6 MX+B

Definition

This mathematical function multiplies a measurement reading (X) by a specified scale factor (M) and add an offset (B) automatically. The answer (Y) will then be shown on the display according to the following equation.

$$Y=MX+B$$

This is especially useful when user needs to do slope calculations on a series of measurements.

The values of the "M" and "B" can be changed through the configuration of this function and they are stored in a volatile memory and will be cleared after the meter has been turned off or a remote interface reset. User can either use front panel or remote interface to perform this

function and set these two constant.

How to use MX+B function

You can use MX+B function from the front panel operation or the remote interface operation.

Front Panel Operation

To set the values of M and B, user needs to configure this math function by pressing CONFIG and SHIFT + %. Use ? and ? to switch between M and B. Press ENTER on your selection. Then use ? and ? to move through the digits and use ? and ? to increase or decrease the number to a desired value. Press ENTER to set the value. User needs to set the values of M and B first. Then Select a measurement function and press SHIFT + % to activate MX+B function as shown as **Figure 4-20**.

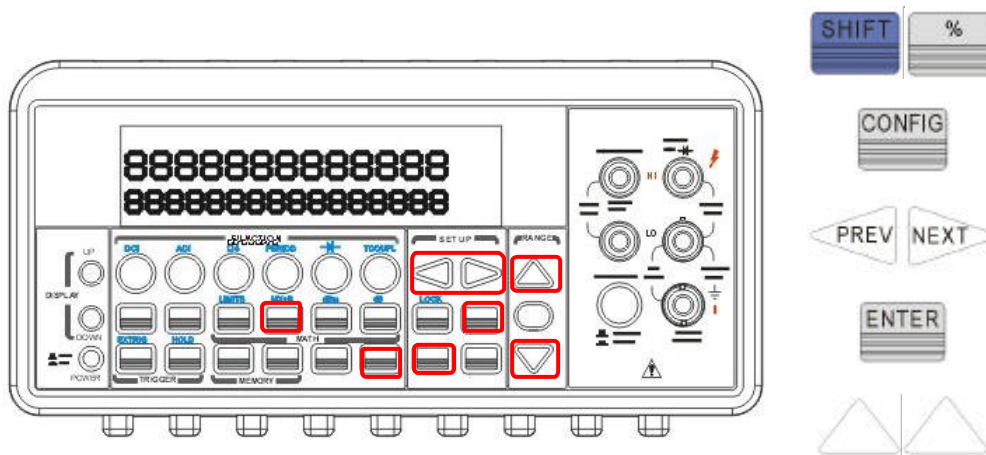

Figure 4-20

Remote Interface Operation

Use the following commands to enable and configure MX+B function:

CALCulate:FUNCTION MXB

CALCulate:STATE { OFF | ON }

CALCulate:STATE?

CALCulate:MXB:MMFactor { <value> | MI Nimum | MAXimum }

CALCulate:MXB:MMFactor? [MI Nimum | MAXimum]

CALCulate:MXB:MBFactor { <value> | MI Nimum | MAXimum }

CALCulate:MXB:MBFactor? [MI Nimum | MAXimum]

4.3.7 dB/dBm

A. dB

Definition

The dB feature takes a DC or AC voltage measurement and displays it in decibel unit in correspondence to a relative reference value. The calculation of dB is listed below:

$$dB = 20 \times \log\left(\frac{V_{in}}{V_{ref}}\right)$$

or

$$dB = (\text{Input signal in dBm}) - (\text{relative value in dBm})$$

? **NOTE:** The V_{in} is the input signal and the V_{ref} is the relative reference.

The dB measurement is applied to DC and AC voltage only. The relative value is adjustable and is stored in a volatile memory. The range for the relative value is between 0 dBm and ± 200 dBm.

How to set the relative value

User can either manually select a number for the relative reference or let the multimeter take the first reading (0 dB).

Front Panel Operation

Press CONFIG + SHIFT + NULL buttons, and then use ? and ? to move through the digits and ? and ? buttons to increase or decrease the numbers to your desired value. Press ENTER to set the value. The locations of the buttons are shown with red rectangle frames in **Figure 4-21**.

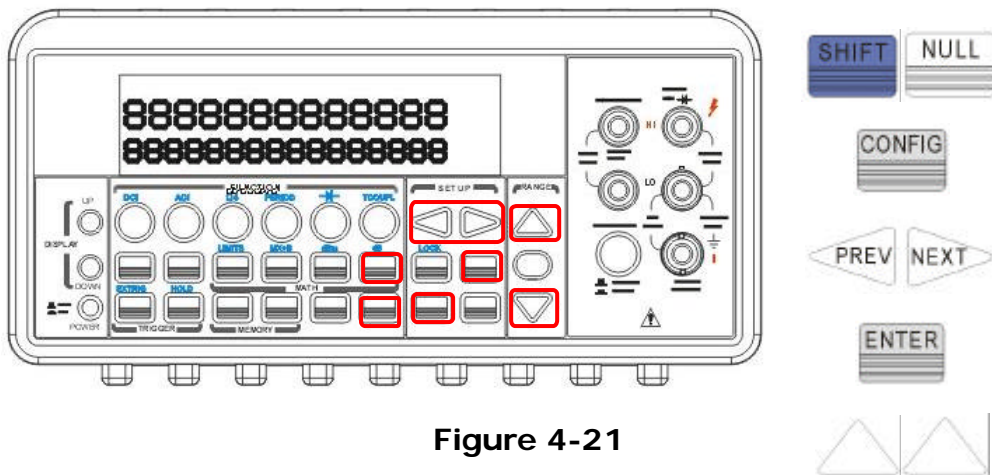

Figure 4-21

How to make a dB measurement

- Select the measurement function by pressing one of DCV and ACV buttons.
- Enable the dB operation by pressing SHIFT + NULL buttons.
- After enabling the dB operation, user can set or alter the dB relative value as mentioned above.
- Observe the displayed reading.

Figure 4-22 shows the locations of these buttons with red rectangle frames.

? Note: Press SHIFT+NULL again to disable this feature. The “MATH” annunciator on the display indicates the state of a mathematical feature.

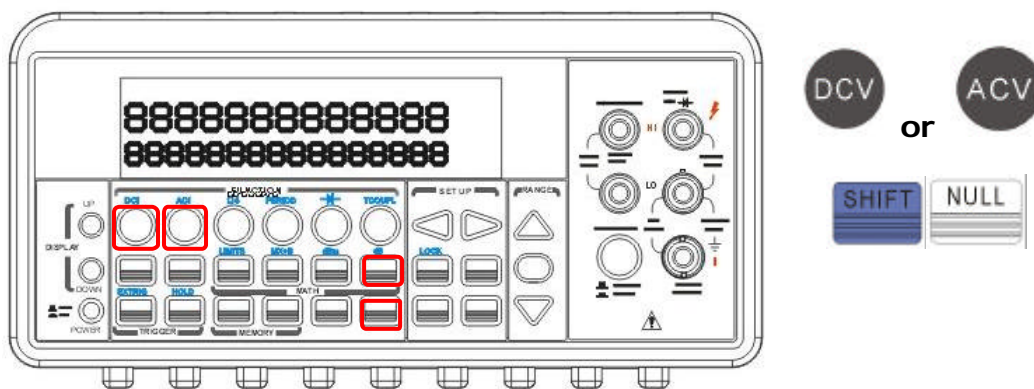

Figure 4-22

Remote Interface Operation

Use the following commands from your PC terminal to make the dB measurement:

CALCulate:FUNCtion DB

CALCulate:STATe {OFF|ON}

CALCulate:STATe?

CALCulate:DB:REFerence { <value> |MI Nimum|MAXimum}

B. dBm

Definition

With dBm selected, a voltage measurement is displayed as the level of power, relative to 1 milliwatt, dissipated through a reference resistance. The reference resistance is adjustable in M3500A. The calculation of dBm

is defined as below:

$$dB_m = 10 \times \log \left(\frac{V_{in}^2}{Z_{ref}} \right) / 1mW$$

? Note: V_{in} is the input signal voltage. Z_{ref} is the reference resistance.

? Note: Change of reference resistance will not affect the stored relative reference value.

- The Zref is adjustable with a range from 50? to 8000 ?. The default value is 600 ?.
- The user selected reference value is stored in a volatile memory and will be cleared after the multimeter has been power-off.
- This feature is available for DCV and ACV only.

How to set the reference resistance

User can set the reference resistance either through the front panel operation or the remote interface operation.

Front Panel Operation

Press CONFIG + SHIFT + MIN/MAX, then use ? and ? to move through the digits and ? and ? to increase or decrease the numbers to a desired value. Press ENTER to set the value. The locations of the buttons are shown with red rectangle frames in **Figure 4-23**.

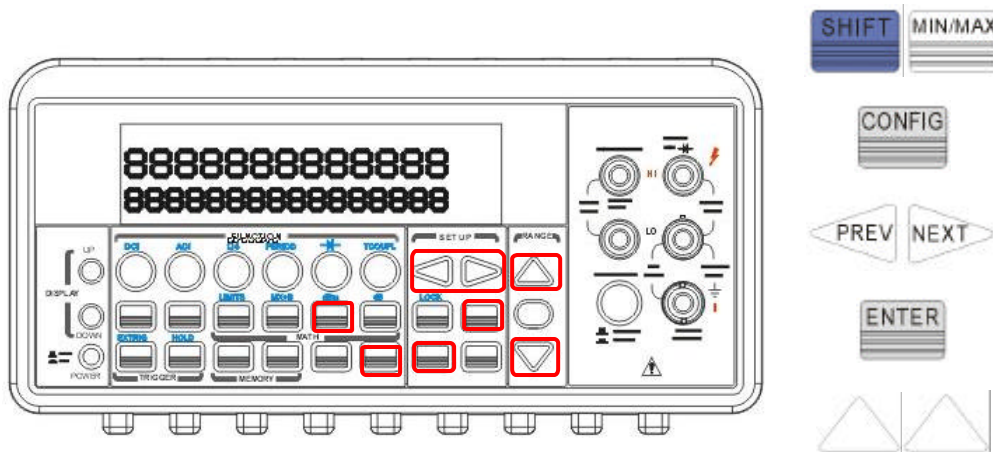

Figure 4-23

How to make a dBm measurement

- Select a measurement function by pressing DCV or ACV button. The dBm feature is only available for DCV and ACV only.
- To enable dBm, press SHIFT + MIN/MAX buttons.
- After enabling the dBm operation, user can select the reference resistance as mentioned above. The default for the reference resistance is 600 Ω.

The locations of the buttons are shown with red rectangle frames in **Figure 4-24**.

? Note: Press SHIFT+MIN/MAX again to disable this feature. The "MATH" annunciator on the display indicates the state of a mathematical feature.

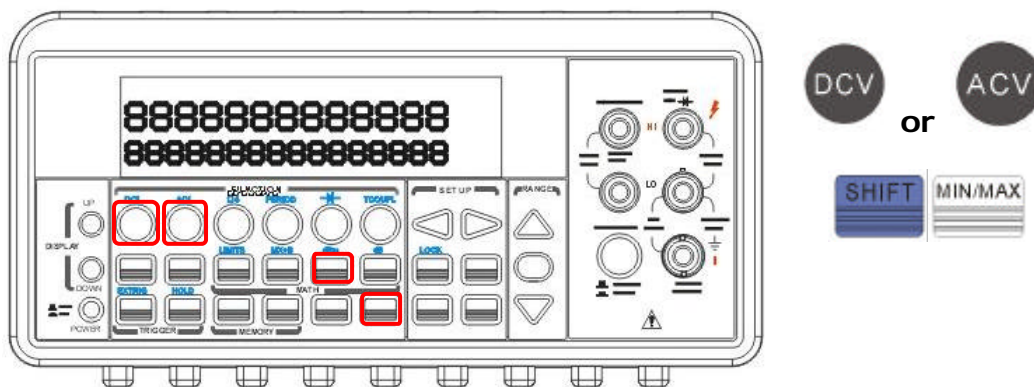

Figure 4-24

Remote Interface Operation

Use the following commands to enable dBm feature or to set the reference resistance:

CALCulate:FUNCtion DBM

CALCulate:STATe {OFF|ON}

CALCulate:STATe?

CALCulate:DBM:REFerence { <value> |MI Nimum|MAXimum }

4.4 Other System Related Operations

Each system related operation performs a task that is not measurement related but plays an important role in making your measurements.

4.4.1 Display

M3500A has a 5x7 dot matrix, dual-display with three-color (White, Red and Yellow) annunciators for a better view. A maximum 13 characters are allowed for upper row dot-matrix display and a maximum 16 characters are allowed for lower row dot-matrix display as shown on **Figure 4-25**. User has an option to turn off the display for a faster measurement without waiting for display, or when the measurement is done through the remote interface operations on their PC terminal.

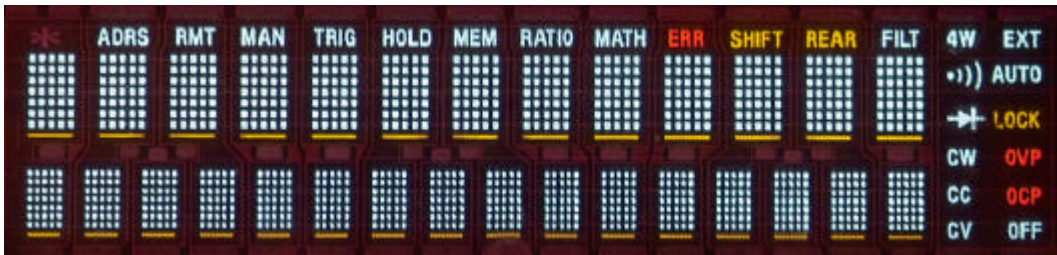

Figure 4-25

When the display is turned off, an "OFF" will be lit at the lower right corner of the display screen. This doesn't mean the display is POWER-OFF, but only that the measurement readings will not be sent to the display. This option will accelerate the measurement process because there is no I/O delay. But turning off the display will not affect the messages displayed from the RECALL, MENU and CONFIG operations.

User can send a message through the remote interface from their PC terminal to the lower row display and will substitute the original display.

Default

The display default is "ON". The "On/Off" selection made by user is stored in a volatile memory and the default "ON" will be restored when the meter is power-off.

How to control the display

You can control the display through the front panel operation or through the remote interface operation. The remote interface operation has higher priority over the front panel operation.

Front Panel Operation

Use the following steps to control the display: Press MENU button then use \leftarrow and \rightarrow buttons to locate "SYSTEM" submenu. Press ENTER to select it, and then again use \leftarrow and \rightarrow buttons to locate "DISPLAY" submenu. Press ENTER to select it, and then find ON or OFF by using \leftarrow and \rightarrow buttons. Press ENTER on your selection. The locations of the buttons are shown with red rectangle frames in **Figure 4-26**.

Procedures: MENU \leftarrow SYSTEM \leftarrow DISPLAY \leftarrow {ON|OFF}

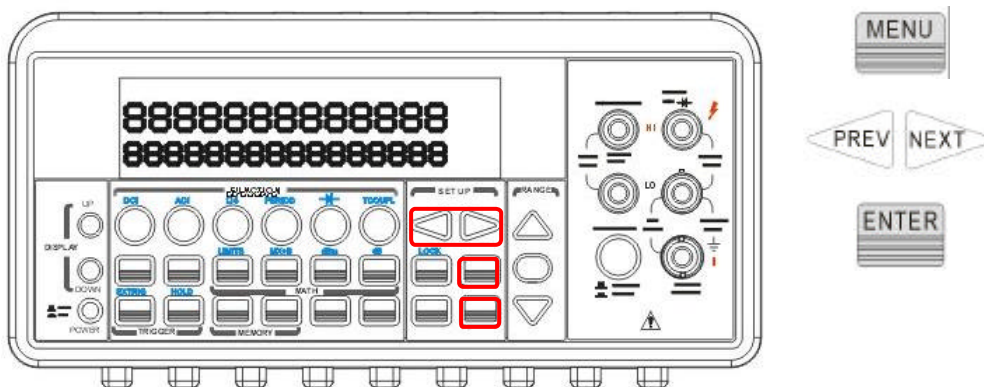

Figure 4-26

Remote Interface Operation

The following commands show how to control the display as well as how to send a message to the display:

DISPlay {OFF|ON} (turns off or turns on the display)

DISPlay:TEXT <quoted string> (displays the string you type in)

DISPlay:TEXT:CLEAr (clears the message displayed)

4.4.2 Beeper

M3500A multimeter beeps when some certain conditions are met or when an error occurs. But there may be time you want to disable the beeper for some operations. Although you can turn off the beeper, the click sound you hear when a button is pressed will not be disabled. The beeper state is stored in a volatile memory and the default will be restored when the meter has been turned off or after a remote interface reset.

By disabling the beeper you will not hear the meter beeps when:

- a new minimum or maximum is found in Min/Max operation.
- a stable reading is detected and held.
- the test voltage is within the limits in diode testing.
- the source signal fails the limit testing.

After the beeper is disabled, the meter still emits a tone when:

- an error occurs.
- any button on the front panel is pressed.
- the threshold value is exceeded in continuity testing.

Default

The beeper is enabled when it is shipped from the factory.

How to control the beeper

User can control the beeper from either the front panel operation or the remote interface operation.

Front Panel Operation

Follow the procedure below to disable or enable the beeper: Press MENU button then use ? and ? buttons to find SYSTEM menu. Press ENTER to choose it, and then again use ? and ? buttons to find BEEP menu. Press ENTER to choose it, and then find ON or OFF by using ? and ? buttons. Press ENTER on your selection. The locations of the buttons are

shown with red rectangle frames in **Figure 4-27**.

Procedures: MENU ? SYSTEM ? BEEP? {ON|OFF}

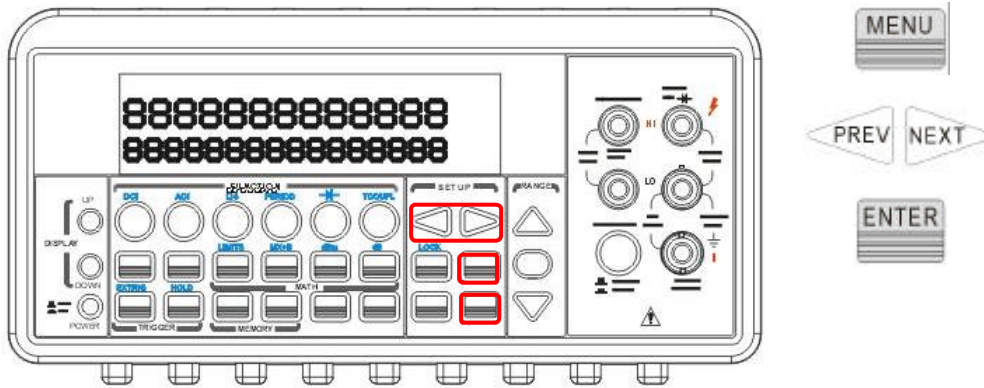

Figure 4-27

Remote Interface Operation

The following commands show how to use the remote interface operation to disable or enable the beeper:

SYSTEM:BEEPer

SYSTEM:BEEPer:STATe {OFF|ON}

4.4.3 Reading Memory (Store & Recall)

M3500A has a memory capacity of 2000 readings. The readings are stored in first-in-first-out order and the memory type is volatile, which means the stored readings will be cleared when the multimeter is power-off. The reading memory feature can be used for all measurement functions, math operations, trigger operations and reading hold.

How to use the reading memory

User can store the readings and access to the stored readings through either the front panel operation or the remote interface operation.

? Note: Each datum stored from M3500A to remote interface will be in a first in and first out condition.

Front Panel Operation

Before using the reading memory feature, user needs to select a measurement function (or the math function) first and then select the trigger mode.

To store readings, use the following steps:

Press STORE button, and the multimeter will start to store the readings produced until the specified number of readings is reached. The default number of readings to store is 100. To change this number, press CONFIG and then STORE buttons. Then use ? and ? buttons to move between the digits and ? and ? buttons to increase or decrease numbers as desired. When ready, press ENTER button. The default number of readings will be restored when the meter has been turned off. The location of the buttons are shown with red rectangle frames in **Figure 4-28**.

? Note: The MEM annunciator will be lit while the multimeter stores readings and be turned off when the specified number of readings is reached.

Procedures: CONFIG +STORE? <NUMBER>

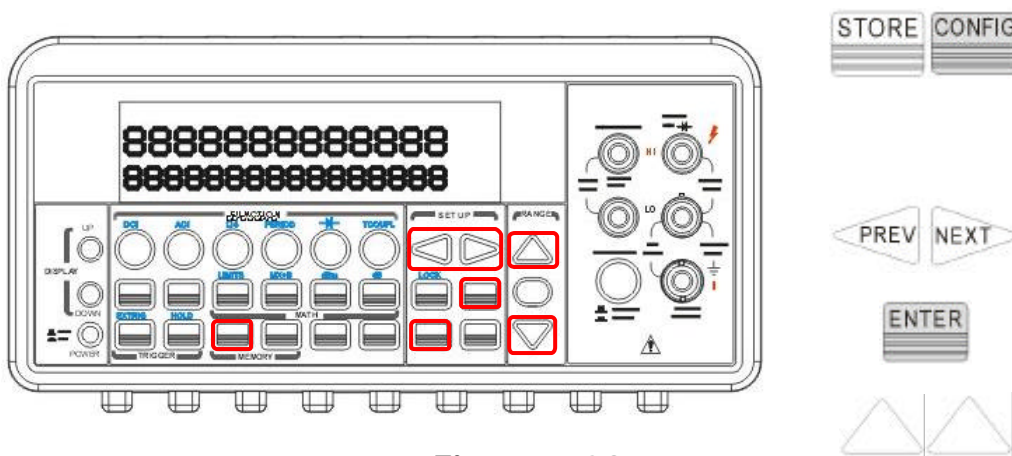

Figure 4-28

To recall the stored readings, use the following steps:

Press RECALL button, and the multimeter will display all the stored readings starting from the first reading. Use \leftarrow and \rightarrow or \triangle and ∇ buttons to move from the first reading to the last reading the meter has stored. The locations of the buttons are shown with red rectangle frames in **Figure 4-29**.

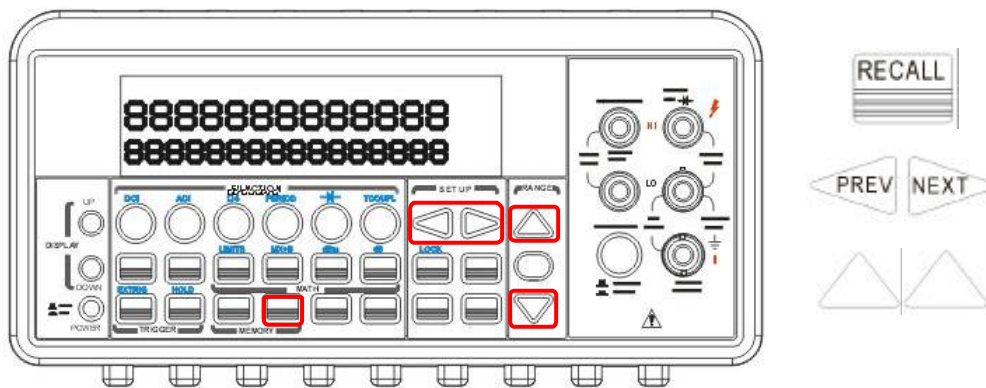

Figure 4-29

Remote Interface Operation

Users can use the following commands from their PC terminals to store or retrieve readings in the memory. In addition, the number for STORE function only can be set through front panel.

INITiate (This command tells the meter to be on “wait-for-trigger” state. After a measurement is taken, measurement readings will be placed in the memory.)

FETCh? (Use this command to retrieve stored readings.)

DATA:POINTs? (Use this command to query the number of stored readings.)

4.4.4 Sensitivity Band (Hold)

The reading hold function captures and holds a stable reading on the display. The multimeter beeps and holds the value when it detects a stable reading. The sensitivity band in reading hold decides which reading is stable enough. This band is expressed as a percent of reading on the selected range. The multimeter considers a reading stable when

three consecutive values are within the band. User has an option to adjust this sensitivity band.

Default

The default band is 0.1%. User's selection is stored in a volatile memory and it will be cleared after the meter has been turned off.

How to adjust the sensitivity band

You can adjust the sensitivity band through either the front panel operation or the remote interface operation.

Front Panel Operation

In order to adjust the sensitivity band, please press MENU button then use \leftarrow and \rightarrow buttons to find "TRIG" submenu. Press ENTER to select it. Then again use \leftarrow and \rightarrow buttons to find "READ HOLD" submenu. Press ENTER to choose it. Then use \leftarrow and \rightarrow buttons to choose a desired band. Press ENTER to set the desired sensitivity band. The locations of the buttons are shown with red rectangle frames in **Figure 4-30**.

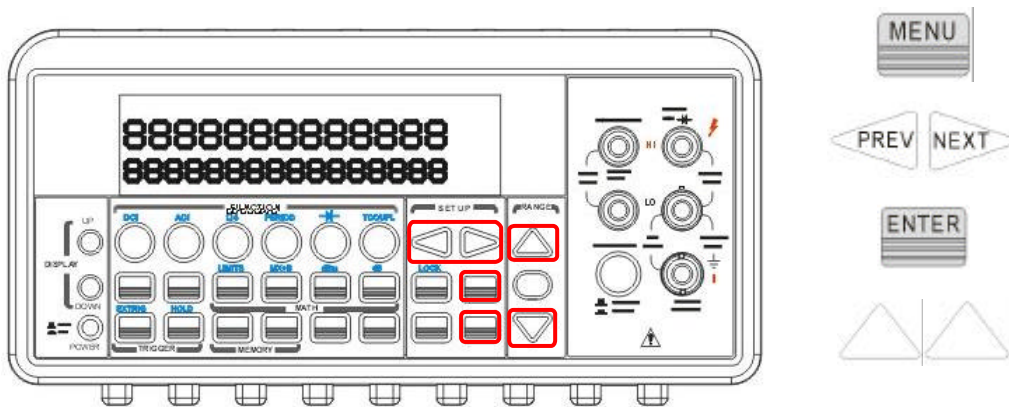
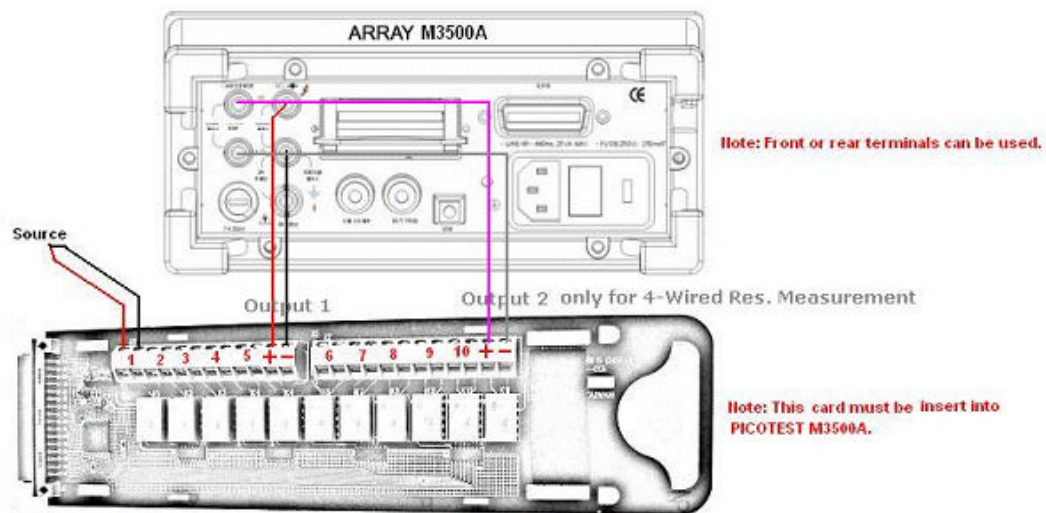

Figure 4-30

4.4.5 Scanning (Scan)

User can purchase an optional internal scanner card to be used with M3500A as the following picture shown. This multipoint scanner card lets you switch and scan up to 10 channels of input signals. User can open

and close individual channels, set scan count and scan interval, store measurement readings and activate measuring through channels defined with different measurement functions. The measurements are taken through all defined channels in sequence. The scan count limits the total number of measurements the multimeter makes through all defined channels in one single scanning operation. The scan interval is the period of time the multimeter waits before it makes a measurement through the first defined channel. The configuration made by user is stored in a volatile memory and will be cleared after the meter is turned off.



? Note: The output 2 is only for 4-wired resistance measurement. Please refer to the above picture for more connection information. When you use 4-wired resistance measurement with scanner card, please note that the channel 1 is relative to the channel 6, channel 2 to channel 7 and so on.

? Note: Setting range of scanner card is only limited on DCV, DCI, ACV, ACI and Resistance functions.

How to program each channel with measurement function

Press CONFIG + SHIFT + DIGITS for scanning configuration. Use ? and ? to scroll through submenus. Press ENTER on "SET SCAN CHA" submenu. Use ? and ? to switch from channel 1 to channel 10, and use ? and ? to switch among the measurement functions. Leave an

unused channel with a blank space (----). Press ENTER when ten channels are all defined.

How to configure scan count, scan interval and store measurement readings

Press CONFIG + SHIFT + DIGITS for scanning configuration. Use ? and ? buttons to scroll through submenus. Press ENTER to select "OPERATION" submenu. Use ? and ? to switch among scan count (COUNT), scan interval (TIMER) and store (STORE) options. Then press ENTER on your selection. Use ? and ? to move through the digits and ? and ? to increase or decrease the numbers to a desired value. For STORE option, you can select ON to instruct the meter to store the measurement results for later retrieving or select OFF. Press ENTER to set the value.

How to open and close the channels

Press CONFIG + SHIFT + DIGITS for scanning configuration. Use ? and ? buttons to scroll through submenus. Press ENTER on "----" when you need to close a specific channel. Press ENTER again on "CHANNEL". Use ? and ? to move through the digits and ? and ? to increase or decrease the numbers to the desired channel number. Press ENTER to close the channel. To open all channels, simply press ENTER on "OPEN ALL" option. Press SHIFT + DIGITS to scan.

The locations of the buttons are shown with red rectangle frames in **Figure 4-31**.

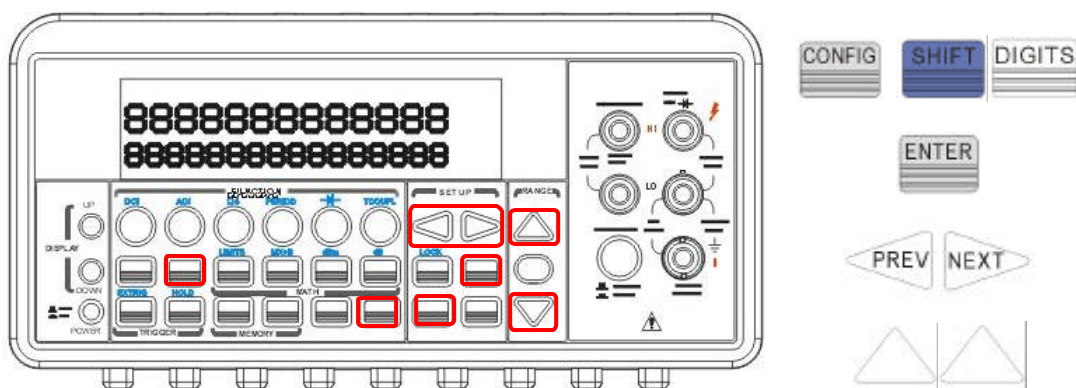

Figure 4-31

4.4.6 Stepping (Step)

Stepping is scanning with a specified time delay between taking input signal through the defined channels.

? **Note: Setting range of scanner card is only limited on DCV, DCI, ACV, ACI and Resistance functions.**

How to program each channel with measurement function

Press CONFIG + SHIFT + FILTER for scanning configuration. Use ? and ? to scroll through submenus. Press ENTER on "SET SCAN CHA" submenu. Use ? and ? to switch from channel 1 to channel 10, and use ? and ? to switch among the measurement functions. Leave an unused channel with a blank space (----). Press ENTER when ten channels are all defined.

How to configure scan count, scan interval and store measurement readings

Press CONFIG + SHIFT + FILTER for scanning configuration. Use ? and ? buttons to scroll through submenus. Press ENTER to select "OPERATION" submenu. Use ? and ? to switch among scan count (COUNT), scan interval (TIMER) and store (STORE) options. Then press ENTER on your selection. Use ? and ? to move through the digits and ? and ? to increase or decrease the numbers to a desired value. For STORE option, you can select ON to instruct the meter to store the measurement results for later retrieving or select OFF. Press ENTER to set the value.

How to open and close the channels

Press CONFIG + SHIFT + FILTER for scanning configuration. Use ? and ? buttons to scroll through submenus. Press ENTER on "----" when you need to close a specific channel. Press ENTER again on "CHANNEL". Use ? and ? to move through the digits and ? and ? to increase or decrease the numbers to the desired channel number. Press ENTER to close the channel. To open all channels, simply press ENTER on "OPEN

ALL” option. Press SHIFT + FILTER to scan as shown as **Figure 4-32**.

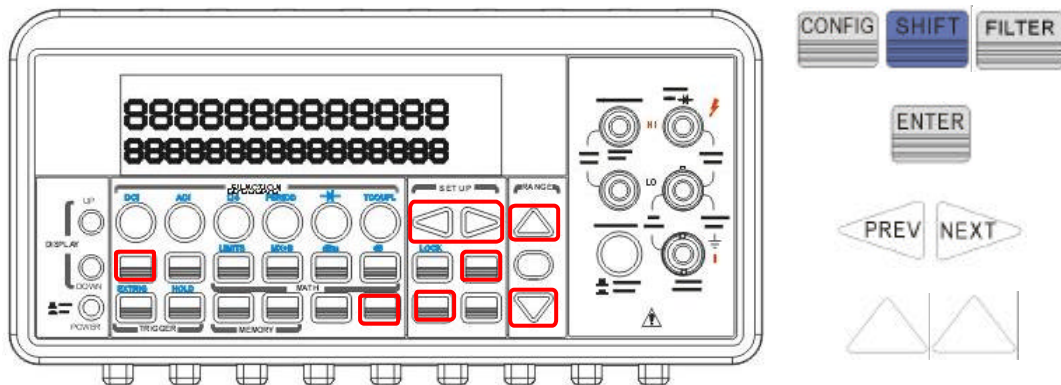

Figure 4-32

4.4.7 Initial Mode

The section contains two selections: “DEFAULT” and “SAVE DATA”. You can select “SAVE DATE” to save the current configuration or select “DEFAULT” to restore the factory value after restarting M3500A. The valid range of “SAVE DATA” is listed in **Table 4-4**.

No.	Items of Save Data	Contents
1	Continuity	Threshold Resistance
2	Diode	Boundary Voltage
3	Temperature (RTD)	Sensor Types & Units
4	Thermocouple	Types, Units, R Junction
5	Step & Scan	Count, Timer
6	dBm	Reference Resistance
7	MX+B	Values: M, B
8	Reading Hold	Sensitivity Band

Table 4-4

How to save the settings

Press MENU and then use \leftarrow and \rightarrow to locate "SYSTEM" submenu. Press ENTER to select it. Again use \leftarrow and \rightarrow to locate "INIT MODE" submenu, and then press ENTER to select it. Use \leftarrow and \rightarrow to switch from "SAVE DATA" and "DEFAULT". Press ENTER on "SAVE DATA" to save your current setting, or press ENTER on "DEFAULT" to return to default setting. The locations of the buttons are shown with red rectangle frames in **Figure 4-33**.

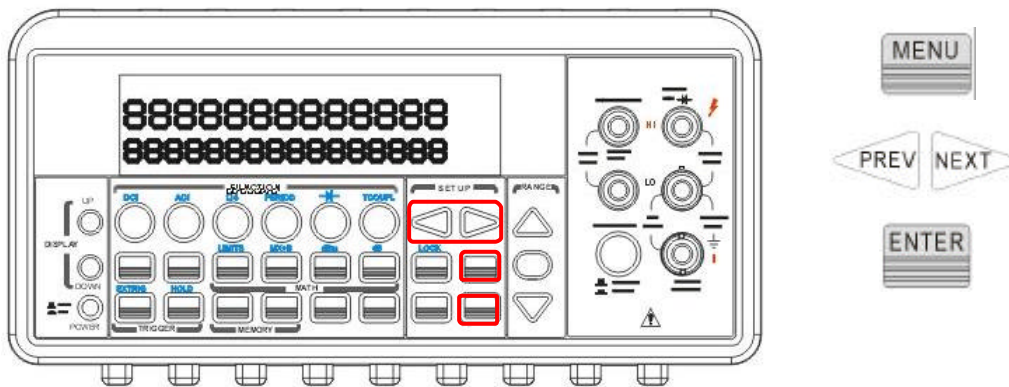

Figure 4-33

4.4.8 Language

M3500A supports two languages: M3500 and A34401.

How to set up the language

Press MENU and then use \leftarrow and \rightarrow to locate "SYSTEM" submenu. Press ENTER to select it. Again use \leftarrow and \rightarrow to locate "LANGUAGE" submenu. Press ENTER to select it. Use \leftarrow and \rightarrow to switch from M3500 and A34401. Press ENTER on your selection. The locations of the buttons are shown with red rectangle frames in **Figure 4-34**.

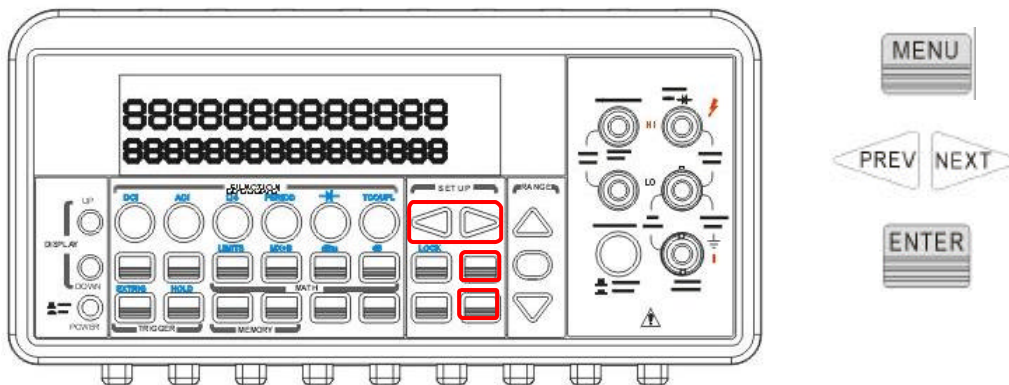

Figure 4-34

4.4.9 Error Condition

The error annunciator on the front panel display tells about the error condition of the multimeter. If there are one or more syntax or hardware errors found, the error annunciator will be lit to inform user. The multimeter stores errors using the first-in-first-out (FIFO) order and it records up to 20 errors in the error queue. The first error detected will be the first error retrieved. Refer to Chapter 6 for the list of error messages.

- The error annunciator will be turned off when you have read the errors in the memory.
- If there is no error found when you check the error queue, the multimeter shows **"NO ERRORS"**.
- If there are more than 20 errors found, the last error in the error queue will be replaced with **"-350"**, means too many errors.
- The error queue is cleared when the multimeter is turned off, or when a *CLS command is received.

How to check the error queue

Press MENU then use ? and ? to locate "SYSTEM" submenu. Press ENTER to select it. Again use ? and ? to locate "ERROR" option. Press ENTER to select it. The message about error queue will show on the display. Refer to Chapter 6 for the descriptions of all the error messages. The locations of the buttons are shown with red rectangle frames in **Figure 4-35**.

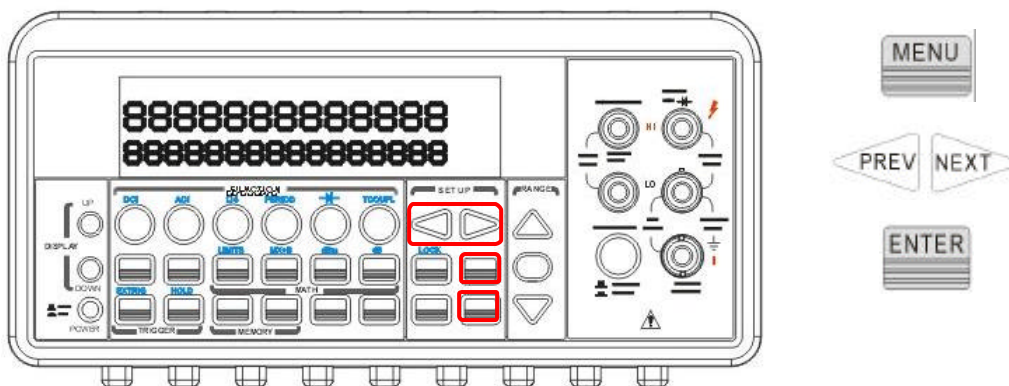

Figure 4-35

4.4.10 Firmware Revision

M3500A has three microprocessors for various internal systems. You can query the multimeter to determine which revision of firmware is installed for each microprocessor.

How to check the firmware revision

Press MENU and then use ? and ? to locate "SYSTEM" submenu. Press ENTER to select it. Again use ? and ? to locate "REVISION" option. Press ENTER to select it. The multimeter gives three numbers in xx-xx-xx format on the display. The first number is the firmware revision number for the measurement microprocessor; the second number is for I/O processor and the third number is for the front-panel processor. The locations of the buttons are shown with red rectangle frames in **Figure 4-36**.

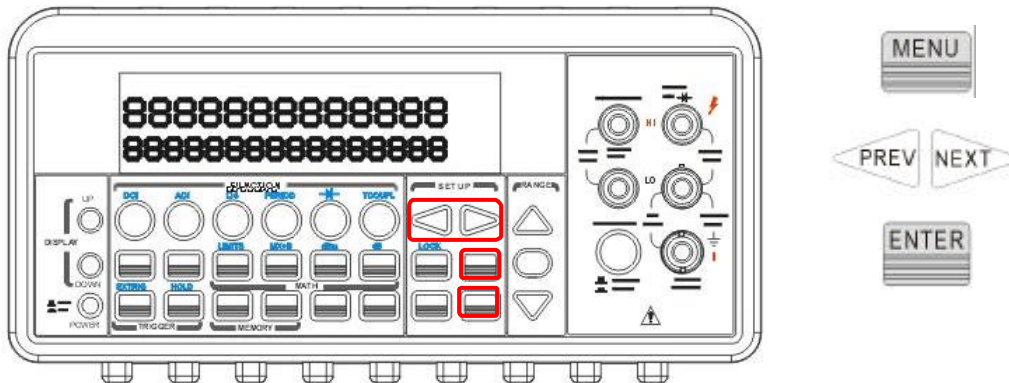

Figure 4-36

4.4.11 Calibration

M3500A will show the latest calibrated date and the next calibration date on the display after following the operation below. The location of the buttons is shown with red rectangle frames in **Figure 4-37**.

How to see the calibration information

Press MENU then locate "CALIBRATE" option using ? and ? . Press

ENTER to select it. Use \leftarrow and \rightarrow to switch from the last calibrated date and the next calibration date.

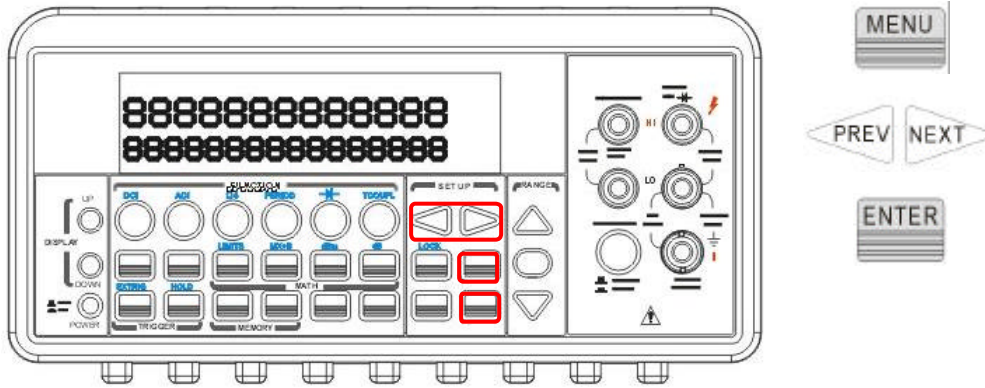

Figure 4-37

5 Remote Interface Operations

M3500A supports two remote interfaces: the built-in USB and optional GPIB (IEEE-488). With GPIB, you will need a GPIB interface card. This chapter lists the SCPI (Standard Commands for Programmable Instrument) commands available to control the multimeter. For the first time to use SCPI, users would better to refer to Appendix B. for SCPI reference.

5.1 Setting Up For Remote Interface

User may use the M3500A application developed by ARRAY to remotely control the multimeter through either USB or GBIP interface.

How to set up for USB interface

The USB cord should be connected well between M3500A and your PC. Install the M3500A application in your PC and execute the program. Click Tool tab for Command Control, then type in your command. The icons and buttons are shown with red rectangle frames in **Figures 5-1, 5-2 and 5-3**.

? Note: The icons, pictures and words will be changed or edited with different versions without informing.

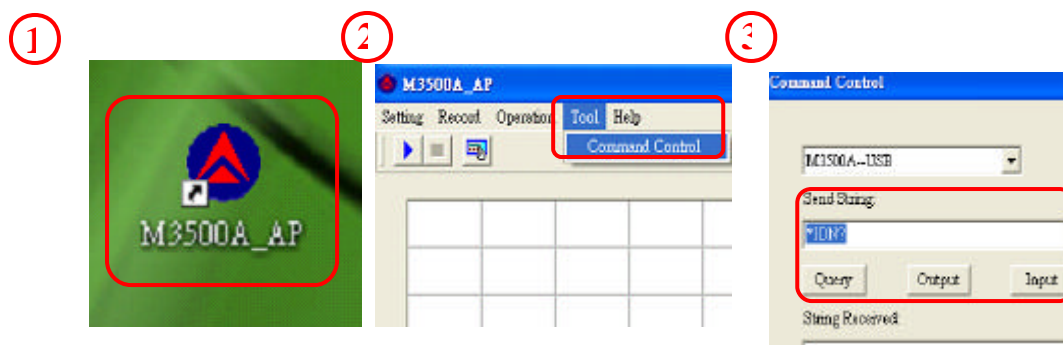

Figure 5-1

Figure 5-2

Figure5-3

How to set up for GPIB interface

Insert GPIB interface card into the interface slot on the rear panel. Install the M3500A application in your PC and execute the program. Click Tool tab for Command Control, then type in your command. The icons and buttons are shown with red rectangle frames in **Figures 5-1, 5-2 and 5-3**.

5.2 Remote Interface Commands

User can instruct the multimeter to take measurements using the SCPI commands after the appropriate setup for their selected remote interface.

The following conventions are used in SCPI command syntax. Triangle brackets (<>) indicates that you must specify a value for the enclosed parameter. The square brackets ([]) indicates that the parameter is optional and can be omitted. The braces ({}) enclose the parameter choices for a given command string. A vertical bar (|) separates several choices for a parameter.

The MEASure? Command

Although it does not offer much flexibility, using the MEASure? Command is the simplest way to program the multimeter for measurements. You select the measurement function, range and resolution, the multimeter automatically sets the other parameters for you, make the measurement and send the result to the output buffer.

MEASure:

VOLTage:DC? {<range>|MIN|MAX|DEF},{<resolution>|MIN|MAX|DEF}

VOLTage:DC:RATio? {<range>|MIN|MAX|DEF},{<resolution>|MIN|MAX|DEF}

VOLTage:AC? {<range>|MIN|MAX|DEF},{<resolution>|MIN|MAX|DEF}

CURRent:DC? {<range>|MIN|MAX|DEF},{<resolution>|MIN|MAX|DEF}

CURRent:AC? {<range>|MIN|MAX|DEF},{<resolution>|MIN|MAX|DEF}

RESistance? {<range>|MIN|MAX|DEF},{<resolution>|MIN|MAX|DEF}

FRESistance? { <range>|MIN|MAX|DEF},{ <resolution>|MIN|MAX|DEF}
FREQuency? { <range>|MIN|MAX|DEF},{ <resolution>|MIN|MAX|DEF}
PERiod? { <range>|MIN|MAX|DEF},{ <resolution>|MIN|MAX|DEF}
CONTInuity?
DIODe?
TCouple?
TEMPerature?

The CONFigure Command

The CONFigure command offers a little more flexibility than the MEASure? Command. The multimeter sets the parameters for the requested function, range and resolution, but does not make the measurements. You have an option to change the configuration. To initiate the measurement, use INITiate or READ? Command.

CONFigure:

VOLTage:DC { <range>|MIN|MAX|DEF},{ <resolution>|MIN|MAX|DEF}
VOLTage:DC:RATio { <range>|MIN|MAX|DEF},{ <resolution>|MIN|MAX|DEF}
VOLTage:AC { <range>|MIN|MAX|DEF},{ <resolution>|MIN|MAX|DEF}
CURRent:DC { <range>|MIN|MAX|DEF},{ <resolution>|MIN|MAX|DEF}
CURRent:AC { <range>|MIN|MAX|DEF},{ <resolution>|MIN|MAX|DEF}
RESistance { <range>|MIN|MAX|DEF},{ <resolution>|MIN|MAX|DEF}
FRESistance { <range>|MIN|MAX|DEF},{ <resolution>|MIN|MAX|DEF}
FREQuency { <range>|MIN|MAX|DEF},{ <resolution>|MIN|MAX|DEF}
PERiod { <range>|MIN|MAX|DEF},{ <resolution>|MIN|MAX|DEF}
CONTInuity
DIODe
TCouple
TEMPerature

CONFigure?

The READ? Command

The READ? Command changes the state of the trigger system from the “idle” state to the “wait-for-trigger” state. When the specified trigger condition requirements are met after the multimeter receives the READ? command, the measurement will be initiated. The results are sent to the output buffer right away. You must enter the reading data into your bus controller or the multimeter will stop making measurements when the output buffer fills. Readings are not stored in the multimeter’s internal memory when using the READ? Command.

Using the READ? Command has a similar effect as using the INITiate command followed immediately by the FETCh? command, except readings are not buffered internally.

The INITiate and FETCh? Commands

These two commands provide the lowest level of control of measurement triggering and reading retrieval, but offer the most flexibility. After you have configured the multimeter, use INITiate command to change the state of the triggering system from the “idle” state to the “wait-for-trigger” state. The multimeter will start the measurements when the specified trigger condition requirements are met after it receives the INITiate command. The results are sent to the internal memory and stored until you are ready to read them.

The FETCh? command sends the data in the multimeter’s internal memory to the output buffer where you can read them into your bus controller.

The SENSE Commands

? NOTE: Default parameters are shown in ***bold italic***.

[SENSe:]

FUNcTION “VOLTage:DC”

FUNcTION “VOLTage:DC:RATio”

FUNcTion "VOLTagE:AC"
FUNcTion "CURRent:DC"
FUNcTion "CURRent:AC"
FUNcTion "RESistance" (2-wire O)
FUNcTion "FRESistance" (4-wire O)
FUNcTion "FREQuency"
FUNcTion "PERiod"
FUNcTion "CONTinuity"
FUNcTion "DIODE"
FUNcTion "TCouple"
FUNcTion "TEMPerature"
FUNcTion?

[SENSe:]

VOLTagE:DC:RANGe { <range>|MINimum|MAXimum}
VOLTagE:DC:RANGe? [MINimum|MAXimum]
VOLTagE:AC:RANGe { <range>|MINimum|MAXimum}
VOLTagE:AC:RANGe? [MINimum|MAXimum]
CURRent:DC:RANGe { <range>|MINimum|MAXimum}
CURRent:DC:RANGe? [MINimum|MAXimum]
CURRent:AC:RANGe { <range>|MINimum|MAXimum}
CURRent:AC:RANGe? [MINimum|MAXimum]
RESistance:RANGe { <range>|MINimum|MAXimum}
RESistance:RANGe? [MINimum|MAXimum]
FRESistance:RANGe { <range>|MINimum|MAXimum}
FRESistance:RANGe? [MINimum|MAXimum]
FREQuency:VOLTagE:RANGe { <range>|MINimum|MAXimum}
FREQuency:VOLTagE:RANGe? [MINimum|MAXimum]
PERiod:VOLTagE:RANGe { <range>|MINimum|MAXimum}
PERiod:VOLTagE:RANGe? [MINimum|MAXimum]

[SENSe:]

VOLTagE:DC:RANGe:AUTO {OFF|**ON**}
VOLTagE:DC:RANGe:AUTO?
VOLTagE:AC:RANGe:AUTO {OFF|**ON**}
VOLTagE:AC:RANGe:AUTO?
CURRent:DC:RANGe:AUTO {OFF|**ON**}

CURRent: DC: RANGe: AUTO?
 CURRent: AC: RANGe: AUTO { OFF | **ON** }
 CURRent: AC: RANGe: AUTO?
 RESistance: RANGe: AUTO { OFF | **ON** }
 RESistance: RANGe: AUTO?
 FRESistance: RANGe: AUTO { OFF | **ON** }
 FRESistance: RANGe: AUTO?
 FREQuency: VOLTage: RANGe: AUTO { OFF | **ON** }
 FREQuency: VOLTage: RANGe: AUTO?
 PERiod: VOLTage: RANGe: AUTO { OFF | **ON** }
 PERiod: VOLTage: RANGe: AUTO?

[SENSe:]

VOLTage: DC: RESolution { <resolution> | MINimum | MAXimum }
 VOLTage: DC: RESolution? [MINimum | MAXimum]
 VOLTage: AC: RESolution { <resolution> | MINimum | MAXimum }
 VOLTage: AC: RESolution? [MINimum | MAXimum]
 CURRent: DC: RESolution { <resolution> | MINimum | MAXimum }
 CURRent: DC: RESolution? [MINimum | MAXimum]
 CURRent: AC: RESolution { <resolution> | MINimum | MAXimum }
 CURRent: AC: RESolution? [MINimum | MAXimum]
 RESistance: RESolution { <resolution> | MINimum | MAXimum }
 RESistance: RESolution? [MINimum | MAXimum]
 FRESistance: RESolution { <resolution> | MINimum | MAXimum }
 FRESistance: RESolution? [MINimum | MAXimum]

[SENSe:]

UNIT { **Cel** | Far | K }
 UNIT?
 TCouple: TYPE { E | J | **K** | N | R | S | T }
 TCouple: TYPE?
 TCouple: RJUNcion: RSElect { REAL | **SIMulated** }
 TCouple: RJUNcion: RSElect?
 TCouple: RJUNcion: SIMulated { <value> | MINimum | MAXimum }
 TCouple: RJUNcion: SIMulated?
 TCouple: RJUNcion: REAL: OFFSet { <value> | MINimum | MAXimum }
 TCouple: RJUNcion: REAL: OFFSet? [MINimum | MAXimum]

[SENSe:]

TEMPerature: RTD: TYPE { **PT100**|D100|F100|PT385|PT3916|USER|SPRTD|NTCT}
TEMPerature: RTD: TYPE?
TEMPerature: RTD: RZERo { <value>|MINimum|MAXimum}
TEMPerature: RTD: RZERo? [MINimum|MAXimum]
TEMPerature: RTD: ALPHa { <value>|MINimum|MAXimum}
TEMPerature: RTD: ALPHa? [MINimum|MAXimum]
TEMPerature: RTD: BETA { <value>|MINimum|MAXimum}
TEMPerature: RTD: BETA? [MINimum|MAXimum]
TEMPerature: RTD: DELTa { <value>|MINimum|MAXimum}
TEMPerature: RTD: DELTa? [MINimum|MAXimum]
TEMPerature: SPRTD: RZERo { <value>|MINimum|MAXimum}
TEMPerature: SPRTD: RZERo? [MINimum|MAXimum]
TEMPerature: SPRTD: A4 { <value>|MINimum|MAXimum}
TEMPerature: SPRTD: A4? [MINimum|MAXimum]
TEMPerature: SPRTD: B4 { <value>|MINimum|MAXimum}
TEMPerature: SPRTD: B4? [MINimum|MAXimum]
TEMPerature: SPRTD: AX { <value>|MINimum|MAXimum}
TEMPerature: SPRTD: AX? [MINimum|MAXimum]
TEMPerature: SPRTD: BX { <value>|MINimum|MAXimum}
TEMPerature: SPRTD: BX? [MINimum|MAXimum]
TEMPerature: SPRTD: CX { <value>|MINimum|MAXimum}
TEMPerature: SPRTD: CX? [MINimum|MAXimum]
TEMPerature: SPRTD: DX { <value>|MINimum|MAXimum}
TEMPerature: SPRTD: DX? [MINimum|MAXimum]

[SENSe:]

VOLTage: DC: NPLCycles { 0.02|0.1 | **1**|10|MINimum|MAXimum}
VOLTage: DC: NPLCycles? [MINimum|MAXimum]
CURRent: DC: NPLCycles { 0.02|0.1 | **1**|10|MINimum|MAXimum}
CURRent: DC: NPLCycles? [MINimum|MAXimum]
RESistance: NPLCycles { 0.02|0.1 | **1**|10|MINimum|MAXimum}
RESistance: NPLCycles? [MINimum|MAXimum]
FRESistance: NPLCycles { 0.02|0.1 | **1**|10|MINimum|MAXimum}
FRESistance: NPLCycles? [MINimum|MAXimum]

[SENSe:]

FREQuency: APERture {0.01|**0.1**|1|MINimum|MAXimum}

FREQuency: APERture? [MINimum|MAXimum]

PERiod: APERture {0.01|**0.1**|1|MINimum|MAXimum}

PERiod: APERture? [MINimum|MAXimum]

[SENSe:]

DETector: BANDwidth {3|**20**|200|MINimum|MAXimum}

DETector: BANDwidth? [MINimum|MAXimum]

[SENSe:]

AVERage: TCONtrol {**MOVing**|REPEAT}

AVERage: TCONtrol?

AVERage: COUNT {<value>|MINimum|MAXimum}

AVERage: COUNT? [MINimum|MAXimum]

AVERage: STATE {OFF|**ON**}

AVERage: STATE?

[SENSe:]

ZERO: AUTO {OFF|ONCE|**ON**}

ZERO: AUTO?

GAIN: AUTO {OFF|ONCE|**ON**}

GAIN: AUTO?

Other Measurement Configuration Commands

INPut:

IMPedance: AUTO {**OFF**|ON}

IMPedance: AUTO?

ROUTe: TERMinals?

ROUTe: CLOSe <channel>

ROUTe: CLOSe?

ROUTe: OPEN

ROUTe: SCAN: FUNction <channel>,{<function>|**"VOLT:DC"**|"VOLT:AC"|

"FREQuency"|"RESistance"|"FRESistance"|"TEMPerature"|"TCouple"|"NONE"}

ROUTe:STATe?

MATH OPERATION Commands

There are eight math operations. Only one of them can be enabled at a time. They either store data for later use or perform mathematical operations on the readings. Note that these eight math operations are available to all measurement functions except continuity and diode testing.

The math operations use one or more internal registers. You can preset the values in some of the registers, while others hold the results of the math operations.

CALCulate:

FUNCtion {**PERCent**|AVERage|NULL|LIMit|MXB|DB|DBM}

FUNCtion?

STATe {**OFF**|ON}

STATe?

CALCulate:

PERCent: TARGet {<value>|MINimum|MAXimum}

PERCent: TARGet? [MINimum|MAXimum]

CALCulate:

AVERage: MINimum?

AVERage: MAXimum?

AVERage: AVERage?

AVERage: COUNT?

CALCulate:

NULL: OFFSet {<value>|MINimum|MAXimum}

NULL: OFFSet? [MINimum|MAXimum]

CALCulate:

LIMit: LOWer {<value>|MINimum|MAXimum}

LIMit: LOWer? [MINimum|MAXimum]

LIMit:UPPer { <value>|MINimum|MAXimum}

LIMit:UPPer? [MINimum|MAXimum]

CALCulate:

MXB:MMFactor { <value>|MINimum|MAXimum}

MXB:MMFactor? [MINimum|MAXimum]

MXB:MBFactor { <value>|MINimum|MAXimum}

MXB:MBFactor? [MINimum|MAXimum]

CALCulate:

DB:REFErence { <value>|MINimum|MAXimum}

DB:REFErence? [MINimum| MAXimum]

CALCulate:

DBM:REFErence { <value>|MINimum|MAXimum}

DBM:REFErence? [MINimum|MAXimum]

DATA:FEED RDG_STORE,{ "CALCulate"|" "}

DATA:FEED?

TRIGGERING

M3500A provides a variety of trigger operations for user. User can select a trigger mode, a trigger source and different trigger settings for a specific measurement. Refer to **Figure 4-8** for triggering system flow chart. Triggering from a remote interface is a multi-step sequence. You must first configure the multimeter by choosing the desired function, range and resolution. Specify the trigger source from which the multimeter will accept the trigger. The multimeter takes immediate internal trigger, a software trigger from a remote interface and external trigger from the rear panel. Then be sure that the multimeter is ready for a trigger (in the "wait-for-trigger" state).

The multimeter accepts a trigger only when it is in the "wait-for-trigger" state. When you have finished configuring the multimeter and have selected a trigger source, you need to place the multimeter in the "wait-for-trigger" state so it will take the trigger and make the

measurement. The INITiate, READ? and MEASure? commands all place the multimeter to the “wait-for-trigger” state.

Triggering Commands

INITiate

READ?

TRIGger:

SOURce {BUS|IMMEDIATE|EXTERNAL}

SOURce?

TRIGger:

DELay {<seconds>|MINimum|MAXimum}

DELay? [MINimum|MAXimum]

TRIGger:

DELay:AUTO {OFF|ON}

DELay:AUTO?

SAMPLE:

COUNT {<value>| MINimum|MAXimum }

COUNT? [MINimum|MAXimum]

TRIGger:

COUNT {<value>| MINimum|MAXimum|INFinite }

COUNT? [MINimum|MAXimum]

SYSTEM-RELATED Commands

Each system related operation performs a task that is not measurement related but plays an important role in making your measurements.

FETCH?

READ?

DISPlay {OFF|**ON**}

DISPlay?

DISPlay:

TEXT <quoted string>

TEXT?

TEXT:CLEar

SYSTem:

BEEPer

BEEPer:STATe {OFF|**ON**}

BEEPer:STATe?

SYSTem:ERRor?

SYSTem:VERSion?

DATA:POINts?

*RST

*IDN?

STATUS REPORTING Commands

SYSTem:ERRor?

STATus:

QUEStionable:ENABLE <enable value>

QUEStionable:ENABLE?

QUEStionable:EVENT?

STATus:PRESet

*CLS

*ESE <enable value>

*ESE?

*ESR?

*OPC

*OPC?

*PSC {0|1}

*PSC?

*SRE <enable value>

*SRE?

*STB?

Other Interface Commands

SYSTem:LOCal

SYSTem:REMOte

IEEE-488.2 COMMON Commands

*CLS

*ESE <enable value>

*ESE?

*ESR?

*IDN?

*OPC

*OPC?

*PSC {0|1}

*PSC?

*RST

*SRE <enable value>

*SRE?

*STB?

*TRG

6 Error Messages

Errors are retrieved in first-in-first-out (FIFO) order. The first error returned is the first error that was stored. When user has read all errors from the queue, the **ERROR** annunciator turns off. M3500A beeps once each time an error occurs.

Should more than 20 errors have existed, the last error stored in the queue (the most recent error) is replaced with -350, "Too many errors". No additional errors are saved until you remove errors from the queue, the multimeter responds with +0, "No error".

The error queue is cleared when power has been off or after a *CLS (clear status) command has been executed. The *RST (reset) command does not clear the error queue.

6.1 Error Type

There is only one type over here, "execution errors". If the errors user can't find here please contact with your seller for help.

6.1.1 Execution Errors

- **-101 Invalid character**

An invalid character was found in the command string.

- **-102 Syntax error**

Invalid syntax was found in the command string.

- **-103 Invalid separator**

An invalid separator was found in the command string.

- **-104 Data type error**

A parameter type error was found in the command string.

- **-105 GET not allowed**

A Group Execute Trigger (GET) is not allowed in the command string.

- **-108 Parameter not allowed**

More parameters were found than needed for the command .

- **-109 Missing parameter**

Not enough parameters were received for the command.

- **-112 Program mnemonic too long**

A command header with too many characters was received.

- **-113 Undefined header**

An invalid command was received.

- **-121 Invalid character in number**

An invalid character was found in the number specified for a parameter value.

- **-123 Numeric overflow**

A numeric parameter with exponent larger than 32000 was found.

- **-124 Too many digits**

A numeric parameter was found whose mantissa contained more than 255 digits, excluding leading zeros.

- **-131 Invalid suffix**

A suffix was incorrectly specified for a numeric parameter.

- **-138 Suffix not allowed**

A suffix was received following a numeric parameter which does not accept a suffix.

- **-148 Character not allowed**

A discrete parameter was received but a character string or a numeric parameter was expected.

- **-151 Invalid string data**

An invalid character string was received.

- **-158 String data not allowed**

A character string was received but not allowed for the command.

- **-160~-168 Block data errors**

Block data is not acceptable.

- **-170~-178 Expression errors**

The meter does not accept mathematical expression.

- **-211 Trigger ignored**

A Group Execute Trigger (GET) or *TRG was received but the trigger was ignored.

- **-213 Trigger deadlock**

A trigger deadlock occurs when the trigger source is BUS and a READ? Command is received

- **-214 Init Ignored**

An INITiate command was received but could not be executed because a measurement was already in progress. Send a device clear to halt a measurement in progress and place the meter in the "idle" state.

- **-221 Settings conflict**

This error can be generated in one of the following situations:

Situation 1: You sent a CONFIGure or MEASURE command with autorange enabled and with a fixed resolution.

Situation 2: You turned math on and then changed to a math operation that was not valid with the present measurement function.

- **-222 Data out of range**

A numeric parameter value is out of range.

- **-223 Too much data**

A character string was too long.

- **-224 Illegal parameter value**

A discrete parameter was received which was not a valid choice for the command.

- **-230 Data Stale**

A FETCh? Command was received but the memory was empty.

- **-350 Too many errors**

The error queue is full.

- **-410 Query INTERRUPTED**

A command was received which sends data to the output buffer, but the output buffer contained data from a previous command.

- **-420 Query UNTERMINATED**

The multimeter was addressed to talk (i.e., to send data over the interface) but a command has not been received which send data to the output buffer.

- **-430 Query DEADLOCKED**

A command was received which generates too much data to fit in the output buffer and input buffer is also full. Command execution continues but all data is lost.

- **-440 Query UNTERMINATED after indefinite response**

The *IDN? Command must be the last query command within a command string.

- **521 Input buffer overflow**

- **522 Output buffer overflow**

- **531 Insufficient memory**

There is not enough memory to store the requested number of readings in internal memory using the INITiate command. The product of the sample count (SAMPLE:COUNT) and the trigger count (TRIGger:COUNT) must not exceed 512 readings.

- **532 Cannot achieve requested resolution**

The multimeter cannot achieve the requested measurement resolution. You may have specified an invalid resolution in the CONFIGure or MEASure command.

- **540 Cannot use overload as math reference**

The multimeter cannot store an overload reading ($9.90000000E+37$) as the math reference for null or dB measurements. The math state is turned off as a result of this condition.

- **550 Command not allowed in local**

The multimeter received a READ? Command while in the local mode.

Appendix

This appendix contains the performance specifications of the M3500A. It covers the AC, DC, Resistance, Temperature, and Frequency/Period characteristics under a variety of conditions. It also contains the general characteristics and accuracy calculations for your convenience. A lot of efforts are made to make sure these specifications serve your needs for production, engineering and/or research purposes. All specification applies to M3500A unless noted otherwise.

A. Specification List

DC Characteristics: Accuracy \pm (% of reading + % of range)

Function	Range	Input Resistance	24-Hour ³ 23° C \pm 1° C
DC Voltage ¹	100.0000 mV	> 10G Ω	0.0030 + 0.0030
	1.000000 V	> 10G Ω	0.0020 + 0.0006
	10.000000 V	> 10G Ω	0.0015 + 0.0004
	100.0000 V	10M Ω	0.0020 + 0.0006
	1000.000 V	10M Ω	0.0020 + 0.0006

¹ a. Using continuous integrating A/D converter.

b. Input bias current: less than 30 pA at 25° C.

c. Input protection: 100 V, all range.

Function	Range	Shunt Resistance	24-Hour ³ 23° C ± 1° C
DCI (DC Current)	10.000000mA	5.1Ω	0.05 + 0.010
	100.00000mA	5.1Ω	0.01 + 0.004
	1.000000A	0.1Ω	0.05 + 0.006
	3.000000A	0.1Ω	0.10 + 0.020

Function	Range	Test Current	24-Hour ³ 23° C ± 1° C
Resistance ² (Specifications are for both 2W and 4W when a Null operation is used.)	100.0000 Ω	1 mA	0.0030 + 0.0030
	1.000000 KΩ	1 mA	0.0020 + 0.0005
	10.00000 KΩ	100 μA	0.0020 + 0.0005
	100.0000 KΩ	10 μA	0.0020 + 0.0005
	1.000000 MΩ	5 μA	0.002 + 0.001
	10.00000 MΩ	500 μA	0.015 + 0.001
	100.0000 MΩ	500 μA 10 MΩ	0.300 + 0.010
Diode Test	1.0000V	1mA	0.002 + 0.010
Continuity 2W	1KΩ	1mA	0.002 + 0.010

² a. Specifications are for 4-wire ohms. For 2-wire ohms, use Math Null function or add 0.2 ohms for additional uncertainty.

b. Max. Lead Resistance: 10% of range per lead for 100Ω and 1KΩ ranges; 1kΩ per lead for all other ranges.

c. Input protection: 1000 V, all ranges.

³ ? Note: 24-hour measurement is relative to calibration accuracy.

Function	Range	Frequency (Hz)	24-Hour ³ 23° C ± 1° C	1 Year 23° C ± 5° C
Period	100mV to 750V	3-5	0.10	0.10
		5-10	0.05	0.05
		10-40	0.03	0.03
		40-300K	0.006	0.01

AC Characteristics: Accuracy ± (% of reading + % of range)

Function	Range	Frequency (Hz)	24-Hour ³ 23° C ± 1° C
ACV (AC RMS Voltage)	100.0000mV	3-5	1.00 + 0.03
		5-10	0.30 + 0.03
		10-20K	0.04 + 0.03
		40-300K	0.10 + 0.05
		50K – 100K	0.55 + 0.08
		100K – 300K	4.00 + 0.50
	1.000000V To 750.000V	3-5	1.00 + 0.02
		5-10	0.35 + 0.02
		10-20K	0.04 + 0.02
		40-300K	0.10 + 0.04
		50K – 100K	0.55 + 0.08
		100K – 300K	4.00 + 0.50

Function	Range	Frequency (Hz)	24-Hour ³ 23° C ± 1° C
ACI (AC RMS Current)	1.000000A	3-5	1.00 + 0.04
		5-10	0.30 + 0.04
		10-5K	0.10 + 0.04
	3.000000A	3-5	1.10 + 0.06
		5-10	0.35 + 0.06
		10-5K	0.15 + 0.06

B. Remote Interface Reference

B.1 An Introduction to the SCPI Language

SCPI (*Standard Commands for Programmable Instruments*) is an ASCII-based instrument command language designed for test and measurement instruments. Refer to "Simplified Programming Overview," for an introduction to the basic techniques used to program the multimeter over the remote interface.

SCPI commands are based on a hierarchical structure, also known as a *tree system*. In this system, associated commands are grouped together under a common node or root, thus forming *subsystems*. A portion of the SENSE subsystem is shown below to illustrate the tree system.

[SENSe:]

VOLTage:

DC:RANGe { <range>|MINimum|MAXimum}

VOLTage:

DC:RANGe? [MINimum|MAXimum]

FREQuency:

VOLTage:RANGe { <range>|MINimum|MAXimum}

FREQuency:

VOLTage:RANGe? [MINimum|MAXimum]

DETEctor:

BANDwidth {3|20|200|MINimum|MAXimum}

DETEctor:

BANDwidth? [MINimum|MAXimum]

ZERO:

AUTO {OFF|ONCE|ON}

ZERO:

AUTO?

SENSe is the root keyword of the command, VOLTage and FREQuency are second-level keywords, and DC and VOLTage are third-level keywords. A *colon* (:) separates a command keyword from a lower-level keyword.

Command Format Used in This Manual

The format used to show commands in this manual is shown below:

VOLTage:DC:RANGe { <range> |MI Nimum|MAXimum}

The command syntax shows most commands (and some parameters) as a mixture of upper- and lower-case letters. The upper-case letters indicate the abbreviated spelling for the command. For shorter program lines, send the abbreviated form. For better program readability, send the long form. For example, in the above syntax statement, VOLT and VOLTAGE are both acceptable forms. You can use upper- or lower-case letters. Therefore, VOLTAGE, volt, and Volt are all acceptable. Other forms, such as VOL and VOLTAG, will generate an error. *Braces* ({ }) enclose the parameter choices for a given command string. The braces are not sent with the command string. A *vertical bar* (|) separates multiple parameter choices for a given command string. *Triangle brackets* (< >) indicate that you must specify a value for the enclosed parameter. For example, the above syntax statement shows the *range* parameter enclosed in triangle brackets. The brackets are not sent with

the command string. You must specify a value for the parameter (such as "VOLT:DC:RANG 10"). Some parameters are enclosed in *square brackets* ([]). The brackets indicate that the parameter is optional and can be omitted. The brackets are not sent with the command string. If you do not specify a value for an optional parameter, the multimeter chooses a default value.

Using the *MIN* and *MAX* Parameters

You can substitute MINimum or MAXimum in place of a parameter for many commands. For example, consider the following command:

```
VOLTage:DC:RANGe { <range> |MI Nimum|MAXimum }
```

Instead of selecting a specific voltage range, you can substitute MIN to set the range to its minimum value or MAX to set the range to its maximum value.

Querying Parameter Settings

You can query the current value of most parameters by adding a question mark (?) to the command. For example, the following command sets the sample count to 10 readings:

```
"SAMP:COUN 10"
```

You can query the sample count by executing:

```
"SAMP:COUN?"
```

You can also query the minimum or maximum count allowed as follows:

```
"SAMP:COUN? MIN"
```

```
"SAMP:COUN? MAX"
```

[J&T14]? **Note:** If you send two query commands without reading the response from the first, and then attempt to read the second response, you may receive some data from the first response followed by the complete second response. To avoid this, do not send a query command

without reading the response. When you cannot avoid this situation, send a device clear before sending the second query command.

SCPI Command Terminators

A command string sent to the multimeter must terminate with a <new line> character. The IEEE-488 EOI (end-or-identify) message is interpreted as a <new line> character and can be used to terminate a command string in place of a <new line> character. A <carriage return> followed by a <new line> is also accepted. Command string termination will always reset the current SCPI command path to the root level.

IEEE-488.2 Common Commands

The IEEE-488.2 standard defines a set of common commands that perform functions like reset, self-test, and status operations. Common commands always begin with an asterisk (*), are four to five characters in length, and may include one or more parameters. The command keyword is separated from the first parameter by a blank space.

Use a semicolon (;) to separate multiple commands as shown below:

```
"*RST; *CLS; *ESE 32; *OPC?"
```

SCPI Parameter Types

The SCPI language defines several different data formats to be used in program messages and response messages.

Numeric Parameters Commands that require numeric parameters will accept all commonly used decimal representations of numbers including optional signs, decimal points, and scientific notation.

Special values for numeric parameters like MINimum, MAXimum, and DEFault are also accepted. You can also send engineering unit suffixes with numeric parameters (e.g., M, K, or u). If only specific numeric values are accepted, the multimeter will automatically round the input numeric parameters. The following command uses a numeric parameter:

```
VOLTage:DC:RANGe { <range> |MI Nimum|MAXimum}
```

Discrete Parameters Discrete parameters are used to program settings that have a limited number of values (like BUS, IMMEDIATE,

EXternal). They have a short form and a long form just like command keywords. You can mix upper- and lower-case letters. Query responses will always return the short form in all upper-case letters. The following command uses discrete parameters:

TRIGger:SOURce {BUS|IMMEDIATE|EXTERNAL}

Boolean Parameters Boolean parameters represent a single binary condition that is either true or false. For a false condition, the multimeter will accept "OFF" or "0". For a true condition, the multimeter will accept "ON" or "1". When you query a boolean setting, the instrument will always return "0" or "1". The following command uses a boolean parameter:

INPut:IMPedance:AUTO {OFF|ON}

String Parameters String parameters can contain virtually any set of ASCII characters. A string must begin and end with matching quotes; either with a single quote or with a double quote. You can include the quote delimiter as part of the string by typing it twice without any characters in between. The following command uses a string parameter:

DISPlay:TEXT <quoted string>

B.2 Output Data Formats

Output data will be in one of formats shown in the table below.

Type of Output Data

Non-reading queries

Single reading (IEEE-488)

Multiple readings (IEEE-488)

Single reading (RS-232)

Multiple readings (RS-232)

Output Data Format

< 80 ASCII character string

SD.DDDDDDDDESDD<nl>
 SD.DDDDDDDDESDD,...,<nl>
 SD.DDDDDDDDESDD<cr><nl>
 SD.DDDDDDDDESDD,...,<cr><nl>
S Negative sign or positive sign
D Numeric digits
E Exponent
 <nl> newline character
 <cr> carriage return character

B.3 The MEASure? Command

MEASure:VOLTage:DC? {<range>|MIN|MAX|DEF},{<resolution>|MIN|MAX|DEF}

Preset and make a dc voltage measurement with the specified range and resolution. The reading is sent to the output buffer.

MEASure:VOLTage:DC:RATio? {<range>|MIN|MAX|DEF},{<resolution>|MIN|MAX|DEF}

Preset and make a dc:dc ratio measurement with the specified range and resolution. The reading is sent to the output buffer. For ratio measurements, the specified range applies to input signal, yet autorange is selected for the reference signal.

MEASure:VOLTage:AC? {<range>|MIN|MAX|DEF},{<resolution>|MIN|MAX|DEF}

Preset and make an AC voltage measurement with the specified range and resolution. The reading is sent to the output buffer. For AC measurement, resolution is fixed at 6 ½ digits. Therefore the resolution parameter only affects the front panel display.

MEASure:CURRent:DC? {<range>|MIN|MAX|DEF},{<resolution>|MIN|MAX|DEF}

Preset and make a dc current measurement with the specified range and resolution. The reading is sent to the output buffer.

MEASure:CURRent:AC? {<range>|MIN|MAX|DEF},{<resolution>|MIN|MAX|DEF}

Preset and make a AC current measurement with the specified range and resolution. The reading is sent to the output buffer. For AC measurement, resolution is fixed at 6 ½ digits. Therefore the resolution parameter only affects the front panel display.

MEASure:RESistance? { <range>|MIN|MAX|DEF},{ <resolution>|MIN|MAX|DEF}

Preset and make a 2-wire Ω measurement with the specified range and resolution. The reading is sent to the output buffer.

MEASure:FRESistance? { <range>|MIN|MAX|DEF},{ <resolution>|MIN|MAX|DEF}

Preset and make a 4-wire Ω measurement with the specified range and resolution. The reading is sent to the output buffer.

MEASure:FREQuency? { <range>|MIN|MAX|DEF},{ <resolution>|MIN|MAX|DEF}

Preset and make a frequency measurement with the specified range and resolution. The reading is sent to the output buffer. For frequency measurements, the meter uses only one "range" for all inputs between 3Hz and 300kHz. With no input signal applied, frequency measurements return "0".

MEASure:PERiod? { <range>|MIN|MAX|DEF},{ <resolution>|MIN|MAX|DEF}

Preset and make a period measurement with the specified range and resolution. The reading is sent to the output buffer. For period measurements, the meter uses only one "range" for all inputs between 0.33 seconds and 3.3 μ sec. With no input signal applied, period measurements return "0".

MEASure:CONTInuity?

Preset and make a continuity measurement. The reading is sent to the output buffer. The range and resolution are fixed at 1k Ω and 5 ½ digits respectively.

MEASure:DIODE?

Preset and make a diode measurement. The reading is sent to the output buffer. The range and resolution are fixed at 1Vdc with 1mA current source and 5 ½ digits respectively.

MEASure:TEMPerature?

Preset and make a temperature measurement with RTD. The reading is sent to the output buffer.

MEASure:TCouple?

Preset and make a temperature measurement with thermocouple. The reading is sent to the output buffer.

B.4 The CONFigure Command

CONFigure:VOLTage:DC { <range> |MIN|MAX|DEF }, { <resolution> |MIN|MAX|DEF }

Preset and configure the multimeter for DC voltage measurements with the specified range and resolution. This command does not initiate the measurement.

CONFigure:VOLTage:DC:RATio { <range> |MIN|MAX|DEF }, { <resolution> |MIN|MAX|DEF }

Preset and configure the multimeter for DC:DC ratio measurements with the specified range and resolution. This command does not initiate the measurement. The specified range applies to the source signal and autorange is selected for the reference signal.

CONFigure:VOLTage:AC { <range> |MIN|MAX|DEF }, { <resolution> |MIN|MAX|DEF }

Preset and configure the multimeter for AC voltage measurements with the specified range and resolution. This command does not initiate the measurement. For AC measurement, resolution is fixed at 6½ digits. Therefore the resolution parameter only affects the front panel display.

CONFigure:CURRent:DC { <range> |MIN|MAX|DEF }, { <resolution> |MIN|MAX|DEF }

Preset and configure the multimeter for DC current measurements with the specified range and resolution. This command does not initiate the measurement.

CONFigure:CURRent:AC { <range> |MIN|MAX|DEF }, { <resolution> |MIN|MAX|DEF }

Preset and configure the multimeter for AC current measurements with the specified range and resolution. This command does not initiate the measurement. For AC measurement, resolution is fixed at 6½ digits. Therefore the resolution parameter only affects the front panel display.

CONFigure:RESistance { <range> |MIN|MAX|DEF }, { <resolution> |MIN|MAX|DEF }

Preset and configure the multimeter for 2-wire Ω measurements with the specified range and resolution. This command does not initiate the measurement.

CONFigure:FRESistance { <range> |MIN|MAX|DEF }, { <resolution> |MIN|MAX|DEF }

Preset and configure the multimeter for 4-wire Ω measurements with the

specified range and resolution. This command does not initiate the measurement.

CONFigure:FREQuency { <range>|MIN|MAX|DEF},{ <resolution>|MIN|MAX|DEF}

Preset and configure the multimeter for frequency measurements with the specified range and resolution. This command does not initiate the measurement. For frequency measurements, the meter uses only one "range" for all inputs between 3Hz and 300kHz. With no input signal applied, frequency measurements return "0".

CONFigure:PERiod { <range>|MIN|MAX|DEF},{ <resolution>|MIN|MAX|DEF}

Preset and configure a period measurement with the specified range and resolution. This command does not initiate the measurement. For period measurements, the meter uses only one "range" for all inputs between 0.33 seconds and 3.3 μ sec. With no input signal applied, period measurements return "0".

CONFigure:CONTInuity

Preset and configure for a continuity measurement. This command does not initiate the measurement. The range and resolution are fixed at 1k Ω and 5½ digits respectively.

CONFigure:DIODE

Preset and configure for a diode measurement. This command does not initiate the measurement. The range and resolution are fixed at 1Vdc with 1mA current source and 5½ digits respectively.

CONFigure:TEMPerature

Preset and configure for a RTD measurement. This command does not initiate the measurement. The resolution is fixed at 6½ digits.

CONFigure:TCouple

Preset and configure for a thermocouple measurement. This command does not initiate the measurement. The resolution is fixed at 6½ digits.

CONFigure?

Query a recent condition of function, and return a quoted string.

B.5 The Measurement configuration command

[SENSe:]FUNctIon "<function>"

Select a measurement function and enclose it in quotes in the command string (FUNC "VOLT:DC"). Use one of the following strings.

<i>VOLTage:DC</i>	<i>VOLTage:AC</i>	<i>VOLTage:DC:RATio</i>
<i>CURRent:DC</i>	<i>CURRent:AC</i>	
<i>RESistance</i> (for 2-wire ohms)	<i>FRESistance</i> (for 4-wire ohms)	
<i>FREQuency</i>	<i>PERiod</i>	<i>CONTinuity</i>
<i>DIODE</i>	<i>TCouple</i>	<i>TEMPerature</i>

[SENSe:]FUNctIon?

Query the measurement function and return a quoted string.

[SENSe:]<function>:RANGe {<range>|MINimum|MAXimum}

Select a range for the selected function. For frequency and period measurements, range applies to the signal's input voltage, not its frequency (use FREQuency:VOLTage or PERiod:VOLTage). MIN selects the lowest range for the selected function. MAX selects the highest range.

[SENSe:]<function>:RANGe? [MINimum|MAXimum]

Query the range for the selected function. For frequency and period, use FREQuency:VOLTage or PERiod:VOLTage. Autorange thresholds: Down range at <10% of range; Up range at >120% of range.

[SENSe:]<function>:RANGe:AUTO {OFF|ON}

Disable or enable autorange for the selected function.

[SENSe:]<function>:RANGe:AUTO?

Query the autorange setting. Return "1" (ON) or "0" (OFF).

[SENSe:]<function>:RESolution {<resolution>|MINimum|MAXimum}

Set resolution for the selected function (not valid for frequency, period, or ratio). Specify the resolution in the same units as the measurement function, not in number of digits. MIN selects the smallest value accepted, which gives the most resolution. MAX selects the largest value accepted which gives the least

resolution.

[SENSe:]<function>:RESolution? [MINimum|MAXimum]

Query the resolution for the selected function.

[SENSe:]UNIT {Cel|Far|K}

Select units for temperature measurement. Cel means Celsius, Far means Fahrenheit, and K means Kelvin.

[SENSe:]UNIT?

Query units for temperature measurement.

[SENSe:]TCouple:TYPE {E|J|K|N|R|S|T}

Select thermocouple sensor type.

[SENSe:]TCouple:TYPE?

Query thermocouple sensor type.

[SENSe:]TCouple:RJUNction:RSElect {REAL|SIMulated }

Select a reference junction type, real or simulated.

[SENSe:]TCouple:RJUNction:RSElect?

Query the reference junction type, real or simulated.

[SENSe:]TCouple:RJUNction:SIMulated {<value>|MINimum|MAXimum}

Set the default temperature of the simulated reference junction.

[SENSe:]TCouple:RJUNction:SIMulated?

Query the default temperature of the simulated reference junction.

[SENSe:]TCouple:RJUNction:REAL:OFFSet {<value>|MINimum|MAXimum}

Set the offset voltage of the real reference junction.

[SENSe:]TCouple:RJUNction:REAL:OFFSet? [MINimum|MAXimum]

Query the offset voltage of the real reference junction.

[SENSe:]TEMPerature:RTD:TYPE {PT100|D100|F100|PT385|PT3916|USER|SPRTD|NTCT}

Select the RTD type for temperature measurement with RTD.

[SENSe:]TEMPerature:RTD:TYPE?

Query the RTD type for temperature measurement with RTD.

[SENSe:]TEMPerature:RTD:RZERO { <value> |MI Nimum|MAXimum}

Set the R-Zero constant for the user defined RTD type.

[SENSe:]TEMPerature:RTD:RZERO? [MI Nimum|MAXimum]

Query the R-Zero constant for the user defined RTD type.

[SENSe:]TEMPerature:RTD:ALPHa { <value> |MI Nimum|MAXimum}

Set the alpha constant for the user type.

[SENSe:]TEMPerature:RTD:ALPHa? [MI Nimum|MAXimum]

Query the alpha constant for the user type.

[SENSe:]TEMPerature:RTD:BETA { <value> |MI Nimum|MAXimum}

Set the beta constant for the user type.

[SENSe:]TEMPerature:RTD:BETA? [MI Nimum|MAXimum]

Query the beta constant for the user type.

[SENSe:]TEMPerature:RTD:DELTA { <value> |MI Nimum|MAXimum}

Set the delta constant for the user type.

[SENSe:]TEMPerature:RTD:DELTA? [MI Nimum|MAXimum]

Query the delta constant for the user type.

[SENSe:]TEMPerature:SPRTD:RZERO { <value> |MI Nimum|MAXimum}

Set the sensor R value at 0 degree Celsius.

[SENSe:]TEMPerature:SPRTD:RZERO? [MI Nimum|MAXimum]

Query the sensor R value at 0 degree Celsius.

[SENSe:]TEMPerature:SPRTD:A4 { <value> |MI Nimum|MAXimum}

Set the A4 coefficient.

[SENSe:]TEMPerature:SPRTD:A4? [MI Nimum|MAXimum]

Query the A4 coefficient.

[SENSe:]TEMPerature:SPRTD:B4 { <value> |MI Nimum|MAXimum}

Set the B4 coefficient.

[SENSe:]TEMPerature:SPRTD:B4? [MI Nimum|MAXimum]

Query the B4 coefficient.

[SENSe:]TEMPerature:SPRTD:AX { <value> |MI Nimum|MAXimum}

Set the A coefficient.

[SENSe:]TEMPerature:SPRTD:AX? [MI Nimum|MAXimum]

Query the A coefficient.

[SENSe:]TEMPerature:SPRTD:BX { <value> |MI Nimum|MAXimum}

Set the B coefficient.

[SENSe:]TEMPerature:SPRTD:BX? [MI Nimum|MAXimum]

Query the B coefficient.

[SENSe:]TEMPerature:SPRTD:CX { <value> |MI Nimum|MAXimum}

Set the C coefficient.

[SENSe:]TEMPerature:SPRTD:CX? [MI Nimum|MAXimum]

Query the C coefficient.

[SENSe:]TEMPerature:SPRTD:DX { <value> |MI Nimum|MAXimum}

Set the D coefficient.

[SENSe:]TEMPerature:SPRTD:DX? [MI Nimum|MAXimum]

Query the D coefficient.

[SENSe:]<function>:NPLCycles {0.02|0.1|1|10|MI Nimum|MAXimum}

Set the integration time in number of power line cycles for the selected function.

This command is valid only for DCV, DCI, 2-wire ohms and 4-wire ohms.

[SENSe:]<function>:NPLCycles? [MI Nimum|MAXimum]

Query the integration time for the selected function.

[SENSe:]FREQuency:APERture {0.01|0.1|1|MI Nimum|MAXimum}

Set the gate time (or aperture time) for frequency function. Specify 10 ms (4 1/2 digits), 100 ms (default;5 1/2 digits), or 1 second (6 1/2 digits).

[SENSe:]FREQuency:APERture? [MI Nimum|MAXimum]

Query the gate time (or aperture time) for frequency function.

[SENSe:]PERiod:APERture{0.01|0.1|1|MI Nimum|MAXimum}

Set the gate time (or aperture time) for period function. Specify 10 ms (4 1/2 digits), 100 ms (default;5 1/2 digits), or 1 second (6 1/2 digits).

[SENSe:]PERiod:APERture? [MI Nimum|MAXimum]

Query the gate time (or aperture time) for period function.

[SENSe:]DETector:BANDwidth {3|20|200|MI Nimum|MAXimum}

Specify the lowest frequency expected in the input signal. The meter selects the slow, medium or fast ac filter based on the frequency you specify.

[SENSe:]DETector:BANDwidth? [MI Nimum|MAXimum]

Query the ac filter and return the bandwidth.

[SENSe:]ZERO:AUTO {OFF|ONCE|ON}

Disable or enable the auto zero mode. The OFF and ONCE have a similar effect. OFF mode does not issue a new offset measurement until the multimeter goes to the "WAIT-FOR-TRIGGER" state. Parameter ONCE issues an immediate offset measurement.

[SENSe:]ZERO:AUTO?

Query the auto zero mode. Returns "1" (ON) or "0" (OFF or ONCE).

[SENSe:]GAIN:AUTO {OFF|ONCE|ON}

Disable or enable the auto gain mode. The OFF and ONCE have a similar effect. OFF mode does not issue a new offset measurement until the multimeter goes to the "WAIT-FOR-TRIGGER" state. Parameter ONCE issues an immediate offset

measurement.

[SENSe:]GAIN:AUTO?

Query the auto gain mode. Returns "1"(ON) or "0"(OFF or ONCE).

INPut:IMPedance:AUTO{OFF|ON}

Disable or enable the automatic input resistance mode for DC voltage measurements. With AUTO ON, the input resistance is set to >10GO for the 100mV, 1V and 10V ranges. With AUTO OFF, the input resistance is fixed at 10MO for all ranges.

INPut:IMPedance:AUTO?

Query the input resistance mode. Returns "1"(ON) or "0"(OFF).

ROUTE:TERMinals?

Query the multimeter to determine if the front or rear input terminals are selected. Returns "FRON" or "REAR"

B.6 The Math Operation Command

CALCulate:FUNcTion {PERCent|AVERage|NULL|LIMit|MXB|DB|DBM}

Select the math function. Only one function can be enabled at a time. The default function is percent.

CALCulate:FUNcTion?

Query the present math function. Returns PERC, AVER, NULL, LIM, MXB, DB or DBM.

CALCulate:STATe {OFF|ON}

Disable or enable the selected math function.

CALCulate:STATe?

Query the state of the math function. Returns "0"(OFF) or "1"(ON).

CALCulate:PERCent:TARGet { <value>|MINimum|MAXimum}

Set the target value for percent math function. The multimeter clears the value when Min/Max is turned on, when the power has been off or a remote interface

reset.

CALCulate:PERCent:TARGet? [MINimum|MAXimum]

Query the target value for percent math function.

CALCulate:AVERage:MINimum?

Read the minimum value found during the Min/Max operation. The multimeter clears the value when Min/Max is turned on, when the power has been off or a remote interface reset.

CALCulate:AVERage:MAXimum?

Read the maximum value found during the Min/Max operation. The multimeter clears the value when Min/Max is turned on, when the power has been off or a remote interface reset.

CALCulate:AVERage:AVERage?

Read the average value of all readings taken since the Min/Max operation has been enabled. The multimeter clears the value when Min/Max is turned on, when the power has been off or a remote interface reset.

CALCulate:AVERage:COUNT?

Read the number of readings taken since Min/Max has been enabled. The multimeter clears the value when Min/Max is turned on, when the power has been off or a remote interface reset.

CALCulate:NULL:OFFSet { <value> |MINimum|MAXimum }

Store a null value in the multimeter's Null Register. *You must turn on the math operation before writing to the math register.* You can set the null value to any number between 0 and $\pm 120\%$ of the highest range.

CALCulate:NULL:OFFSet?

Query the null value.

CALCulate:LIMit:LOWer { <value> |MINimum|MAXimum }

Set the lower limit for limit testing. You can set the value to any number from 0 to $\pm 120\%$ of the highest range, for the present function.

CALCulate:LIMit:LOWer?

Query the lower limit for the limit testing.

CALCulate:LIMit:UPPer { <value> |MINimum|MAXimum}

Set the upper limit for limit testing. You can set the value to any number from 0 to $\pm 120\%$ of the highest range, for the present function.

CALCulate:LIMit:UPPer?

Query the upper limit for the limit testing.

CALCulate:MXB:MMFactor { <value> |MINimum|MAXimum}

Set the value of M.

CALCulate:MXB:MMFactor? [MINimum|MAXimum]

Query the value of M.

CALCulate:MXB:MBFactor { <value> |MINimum|MAXimum}

Set the value of B.

CALCulate:MXB:MBFactor? [MINimum|MAXimum]

Query the value of B.

CALCulate:DB:REFeRence { <value> |MINimum|MAXimum}

Store a relative value in the dB Relative Register. *You must turn on the math operation before writing to the math register.* You can set the relative value to any number between 0 dBm and ± 200 dBm.

CALCulate:DB:REFeRence? [MINimum|MAXimum]

Query the dB relative value.

CALCulate:DBM:REFeRence { <value> |MINimum|MAXimum}

Set the dBm reference value. Choose from: 50 ~ 8000 ohms.

CALCulate:DBM:REFeRence? [MINimum|MAXimum]

Query the dBm reference value.

DATA:FEED RDG_STORE,{“CALCulate”| “”}

Selects whether readings taken using the INITiate command are stored in the multimeter’s internal memory (default) or not stored at all. In the default state (DATA:FEED RDG_STORE,“CALC”), up to 2000 readings are stored in memory when INITiate is executed. The MEASure? And CONFigure commands automatically select “CALC”. With memory disabled (DATA:FEED RDG_STORE,“”), readings taken using INITiate are not stored. This may be useful with the Min/Max operation since it allows you to determine an average of the readings without storing the individual values. An error will be generated if you attempt to transfer readings to the output buffer using the FETCh? command.

DATA:FEED?

Query the reading memory state. Return “CALC” or “”.

B.7 The Triggering Commands**INITiate**

Change the state of the triggering system from the “idle” state to “wait-for-trigger” state. The meter will start to make measurements when a required triggering condition is met after the INITiate command is received. Readings are stored in memory until you are ready to read them. Use FETCh? command to retrieve your measurements results.

READ?

Change the state of the triggering system from the “idle” state to “wait-for-trigger” state. The meter will start to make measurements when a required triggering condition is met after the READ? Command is received. Readings are sent to the output buffer right away.

TRIGger:SOURce {BUS|IMMediate|EXTernal}

Select a trigger source. The multimeter will accept a software (BUS) trigger, an immediate internal trigger, or a hardware trigger from the rear-panel EXT TRIG terminal.

TRIGger:SOURce?

Query the trigger source.

TRIGger:DELAy { <seconds> |MINimum|MAXimum}

Set a trigger delay time in seconds. The delay is the time between the trigger signal and each sample that follows. Specify a delay time from 0 to 3600 seconds.

TRIGger:DELAy?

Query the trigger delay time.

TRIGger:DELAy:AUTO { OFF|ON}

Disable or enable a automatic trigger delay. The delay is determined by function, range, integration time, and ac filter setting. Specifying a delay time automatically turns off the automatic trigger delay.

TRIGger:DELAy:AUTO?

Query the automatic trigger delay mode. Returns "0" (OFF) or "1" (ON).

SAMPlE:COUNT { <value> |MINimum|MAXimum}

Set the number of readings (samples) the multimeter takes per trigger. Select a number from 1 to 50,000 readings per trigger.

SAMPlE:COUNT ? [MINimum|MAXimum]

Query the sample count.

TRIGger:COUNT { <value> |MINimum|MAXimum|INFinite}

Specify the number of triggers the multimeter will accept before returning to the "idle" state. Select from 1 to 50,000 triggers. The INFinite parameter instructs the multimeter to take triggers continuously. Trigger count is ignored while in local operation.

TRIGger:COUNT? [MINimum|MAXimum|INFinite]

Query the trigger count. Returns "9.90000000E+37" when you select the infinite trigger count.

B.8 The System-Related Commands

FEtCh?

Transfer readings stored in memory by the INITiate command to output buffer where you are able to read them into your bus controller.

READ?

Change the state of the triggering system from the "idle" state to "wait-for-trigger" state. The meter will start to make measurements when a required triggering condition is met after the READ? command is received. Measurement readings are sent to the output buffer immediately.

DISPlay {OFF|ON}

Turn off or on the display.

DISPlay?

Query the display setting. Returns "0" (OFF) or "1" (ON).

DISPlay:TEXT <quoted string>

Show a message on the front panel display. The allowed message can be up to 16 characters in the lower row display; any additional characters will be truncated.

DISPlay:TEXT?

Query the message sent to the front panel display.

DISPlay:TEXT:CLEAr

Clear the message shown on the front panel display.

SYSTem:BEEPer

Issue a single beeping tone.

SYSTem:BEEPer:STATe {OFF|ON}

Disable or enable the beeper.

SYSTem:BEEPer:STATe?

Query the beeper mode. Returns "0" (OFF) or "1" (ON).

SYSTem:ERRor?

Query the multimeter's error queue. Up to 20 errors can be stored in the queue. Errors are retrieved in first-in-first-out (FIFO) order. Each error string may contain up to 80 characters.

SYSTem:VERSion?

Query the present SCPI version.

DATA:POINts?

Query the number of readings stored in the multimeter's internal memory.

***RST**

Reset the multimeter to the power-on configuration. This command can not clear the error queue.

.

***IDN?**

Read the multimeter's identification string (be sure to dimension a string variable with at least 35 characters).

Other Interface Commands**SYSTem:LOCal**

Place the multimeter in the *local* mode. All buttons on the front panel are fully functional.

SYSTem:REMOte

Place the multimeter in the *remote* mode. All buttons on the front panel, except the LOCAL button, are disabled.

B.9 Status Reporting Commands**SYSTem:ERRor?**

Query the multimeter's error queue. Up to 20 errors can be stored in the queue. Errors are retrieved in first-in-first out (FIFO) order. Each error string may contain up to 80 characters.

STATus:QUEStionable:ENABle <enable value>

Enable bits in the Questionable Data enable register. The selected bits are then reported to the Status Byte.

STATus:QUEStionable:ENABle?

Query the Questionable Data enable register. The multimeter returns a binary-weighted decimal representing the bits set in the enable register.

STATus:QUEStionable:EVENT?

Query the Questionable Data event register. The multimeter returns a decimal value which corresponds to the binary-weighted sum of all bits set in the register.

STATus:PRESet

Clear all bits in the Questionable Data enable register.

***CLS**

Clear the Status Byte summary register and all event registers.

***ESE <enable value>**

Enable bits in the Standard Event enable register. The selected bits are then reported to the Status Byte.

***ESE?**

Query the Standard Event enable register. The multimeter returns a decimal value which corresponds to the binary-weighted sum of all bits set in the register.

***ESR?**

Query the Standard event register. The multimeter returns a decimal value which corresponds to the binary-weighted sum of all bits set in the register.

***OPC**

Sets the "operation complete" bit (bit 0) in the Standard Event register after the command is executed.

***OPC?**

Returns "1" to the output buffer after the command is executed.

***PSC {0|1}**

Power-on status clear. Clear the Status Byte and Standard Event register enable masks when power is turned on (*PSC 1). When *PSC 0 is in effect, the Status Byte and Standard Event register enable masks are not cleared when power is turned on. [Stored in non-volatile memory]

***PSC?**

Query the power-on status clear setting. Returns "0" (*PSC 0) or "1" (*PSC 1).

***SRE <enable value>**

Enable bits in the Status Byte enable register.

***SRE?**

Query the Status Byte enable register. The multimeter returns a decimal value which corresponds to the binary-weighted sum of all bits set in the register.

***STB?**

Query the Status Byte summary register. The *STB? command is similar to a serial poll but it is processed like any other instrument command. The *STB? command returns the same result as a serial poll but the "request service" bit (bit 6) is not cleared if a serial poll has occurred.

B.10 SCPI Compliance Information

This section encloses a list of commands that are device-specific to the M3500A. Although not included in the 1999.0 version of the SCPI standard, these commands are designed with the SCPI format in mind and they follow all of the syntax rules of the standard.

Many of the required SCPI commands are accepted by the multimeter but are not described in this manual for simplicity or clarity. Most of these non-documented commands duplicate the functionality of a command already described in this chapter.

MEASure:

CONTInuity?

DIODe?

SAMPlE:

COUNT { <value>|MINimum|MAXimum}

COUNT? [MINimum|MAXimum]

[SENSe:]

FUNcTION "CONTInuity"

FUNcTION "DIODe"

FREQuency: VOLTage: RANGe { <range>|MINimum|MAXimum}

FREQuency: VOLTage: RANGe? [MINimum|MAXimum]

FREQuency: VOLTage: RANGe: AUTO { OFF|ON}

FREQuency: VOLTage: RANGe: AUTO?

PERiod: VOLTage: RANGe { <range>|MINimum|MAXimum}

PERiod: VOLTage: RANGe? [MINimum|MAXimum]

PERiod: VOLTage: RANGe: AUTO { OFF|ON}

PERiod: VOLTage: RANGe: AUTO?

ZERO: AUTO?

CALCulate:

PERCent: TARGeT { <value>|MINimum|MAXimum}

PERCent: TARGeT? [MINimum|MAXimum]

AVERage: MINimum?

AVERage: MAXimum?

AVERage: AVERage?

AVERage: COUNT?

NULL: OFFSet { <value>|MINimum|MAXimum}

NULL: OFFSet? [MINimum|MAXimum]

LIMit: LOWer { <value>|MINimum|MAXimum}

LIMit: LOWer? [MINimum|MAXimum]

LIMit: UPPer { <value>|MINimum|MAXimum}

LIMit: UPPer? [MINimum|MAXimum]

MXB: MMFactor { <value>|MINimum|MAXimum}

MXB: MMFactor? [MINimum|MAXimum]

MXB: MBFactor { <value>|MINimum|MAXimum}

MXB:MBFactor? [MINimum|MAXimum]
DB:REfERENCE { <value>|MINimum|MAXimum}
DB:REfERENCE? [MINimum|MAXimum]
DBM:REfERENCE { <value>|MINimum|MAXimum}
DBM:REfERENCE? [MINimum|MAXimum]

CONFigure:

CONTinuity
DIODE

INPut:

IMPedance: AUTO {OFF|ON}
IMPedance: AUTO?

B.11 IEEE-488 Compliance Information

IEEE-488.2 Common Commands

*CLS
*ESE <enable value>
*ESE?
*ESR?
*IDN?
*OPC
*OPC?
*PSC {0|1}
*PSC?
*RST
*SRE <enable value>
*SRE?
*STB?
*TRG

Dedicated Hardware Lines Addressed Commands

ATN
IFC

REN
SRQ
Attention
Interface Clear
Remote Enable
Service Request Interrupt
DCL
EOI
GET
GTL
LLO
SDC
SPD
SPE
Device Clear
End or Identify Message Terminator
Group Execute Trigger
Go to Local
Local Lock-Out
Selected Device Clear
Serial Poll Disable
Serial Poll Enable

Using Device Clear to Halt Measurements

Device clear is an IEEE-488 low-level bus message which can be used to halt measurements in progress. Different programming languages and IEEE-488 interface cards provide access to this capability through their own unique commands. The status registers, the error queue, and all configuration states are left unchanged when a device clear message is received. Device clear performs the following actions.

- All measurements in progress are aborted.
- The multimeter returns to the trigger "idle state."
- The multimeter's input and output buffers are cleared.
- The multimeter is prepared to accept a new command string.

For RS-232 operation, sending the <Ctrl-C> character will perform the equivalent operations of the IEEE-488 device clear message.

The multimeter's DTR (data terminal ready) handshake line will be true following a device clear message. See "*DTR/DSR Handshake Protocol*," for further details.

TALK ONLY for Printers

You can set the address to "31" which is the *talk only* mode. In this mode, the multimeter can output readings directly to a printer without being addressed by a bus controller (over either HP-IB or RS-232).

For proper operation, make sure your printer is configured in the *listen always* mode. Address 31 is not a valid address if you are operating the multimeter from the HP-IB interface with a bus controller.

If you select the RS-232 interface and then set the HP-IB address to the talk only address (31), the multimeter will *send* readings over the RS-232 interface when in the local mode.

C. About Application Programs

This section provides a brief description for each M3500A sample collection.

Visual Basic

Learn how to create and use INS001 IOUtils components, controls, data access, and more with the Visual Basic sample applications. For an overview and installation details, see [Visual Basic: Explore the Samples](#).

Visual C++

In an MFC application, you can override INS001 IOUtils interfaces in a class as well as provide additional interfaces. The example in this article illustrates how to override an interface in a class while preserving the original interface implementation so that it can be delegated to by the new interface implementation. Browse the [Visual C++ samples code](#); see [Visual C++ DEVQUERY Sample Application](#).

Using MEASure? for a Single Measurement

The following example uses the MEASure? command to make a single ac current measurement. This is the easiest way to program the multimeter for measurements. However, MEASure? does not offer much flexibility. The example is shown in Visual Basic.

Creating the Application

Create a new Visual Basic project as follows:

1. Create a new Standar.EXE project.
2. To set the startup object for a Windows Application to Sub Main
3. Add New Module, and declare a Sub Main().

How to: Change the Startup Object for an Application

The Startup Object property for a project defines the entry point to be called when the application loads; generally this is set to either the main form in your application or to the Sub Main procedure that should run when the application starts. Since Class Libraries do not have an entry point, their only option for this property is (None).

For Windows Applications projects, only forms or classes with a Public Sub Main procedure are available as Startup objects unless you check the Startup with custom Sub Main checkbox; when this option is checked, you must add code in the Sub Main procedure for the form.

? Note: When using a custom Sub Main procedure as the Startup object, code in the Application events (Startup, Shutdown, Startup Next Instance, and Unhandled Exception) is not executed. The Startup Object property can be set in the Application pane of the Project Designer.

To change the startup object

1. With a project selected in Solution Explorer, on the Project menu click Properties.
2. Select the Application pane.
3. Select a Startup object from the Startup object drop-down list.

To set the startup object for a Windows Application to Sub Main

1. With a project selected in Solution Explorer, on the Project menu click Properties.
2. Select the Application pane.
3. Check the Startup with custom Sub Main checkbox.
4. Select Sub Main from the Startup object drop-down list.

LISTING C.1. MEASure.bas--THE Sub Main FUNCTION IS WHERE YOU NEED TO ADD INITIALIZATION CODE.

```
Sub main()  
  
    Dim M3500A As Object  
    Dim Rdg As Double  
  
    ' To assign an object reference using CreateObject  
    Set M3500A = CreateObject("INS001.IOUtills")  
  
    M3500A.Refresh  
    M3500A.Index = 0  
  
    With M3500A  
        .Output = "*RST"           ' Reset M3500A  
        .Output = "*CLS"         ' Clear M3500A status registers  
        .Output = "meas:curr:AC? 1A,0.001MA" ' Set to 1 amp ac range  
    End With  
  
    Rdg = Val(M3500A.Input)  
    Debug.Print " Rdg = "; Rdg  
  
    M3500A.Close  
    Set M3500A = Nothing  
  
End Sub
```

Using CONFigure with a Math Operation

The following example uses CONFigure with the dBm math operation. The CONFigure command gives you a little more programming flexibility than the MEASure? command. This allows you to “incrementally” change the multimeter’s configuration. The example is shown in Visual Basic.

Creating the Application

Create a new Visual Basic project as follows:

1. Create a new Standar.EXE project.
2. To set the startup object for a Windows Application to Sub Main
3. Add New Module, Declare a Sub Main().

LISTING C.2. THE CONFigure FUNCTION.

```
Attribute VB_Name = "Module1"

Sub main()

    ' Set sample count 5 configuration and
    ' read the trigger

    Dim M3500A As Object
    Dim Rdgs As String
    Dim i As Integer ' Array Index
    ' To assign an object reference using CreateObject
    Set M3500A = CreateObject("INS001.IOUtils")

    M3500A.Refresh
    If M3500A.Count = 0 Then
        MsgBox "Connect M3500A device failed.", 48, "Configure sample"
        Exit Sub
    End If
    M3500A.Index = 0
    M3500A.Timeout = 10000          ' Assign timeout period

    With M3500A
        .Output = "*RST"           ' Reset M3500A
        .Output = "*CLS"           ' Clear M3500A status registers
        .Output = "CALC:DBM:REF 50" ' 50 ohm reference resistance
        .Output = "CONF:VOLT:AC 1,0.001" ' Set M3500A to 1 amp ac range
        .Output = "DET:BAND 200"   ' Select 200 Hz (fast) ac filter
        .Output = "SAMP:COUN 5"    ' M3500A will accept 5 triggers
        .Output = "TRIG:SOUR IMM"  ' Trigger source is IMMEDIATE
        .Output = "CALC:FUNC DBM"  ' Select dBm function
        .Output = "CALC:STAT ON"   ' Enable math
        .Output = "READ?"         ' Take readings
        Rdgs = .Input
    End With
```

```
For i = 0 To (5 - 1)      ' print out the 5 times samples reading
    Debug.Print "Rdgs = "; Mid(Rdgs, i * 16 + 1, 15)
Next

End Sub
```

Using the Status Registers

The following example shows how you can use the multimeter's status registers to determine when a command sequence is completed. The example is shown in Visual Basic.

Creating the Application

Create a new Visual Basic project as follows:

1. Create a new Standar.EXE project.
2. After you create the application shell, lay out the Form1 as shown earlier in Figure C.1.
3. Configure the control properties as specified in Table C.1.

Adding Controls to Your Window

The application you are going to build today will have a number of controls on a dialog window, as shown in Figure C.1. When the user selects clicks the Start Readings button t, the routine that sets up the meter will run. Setup M3500A to return an SRQ event when readings are complete.

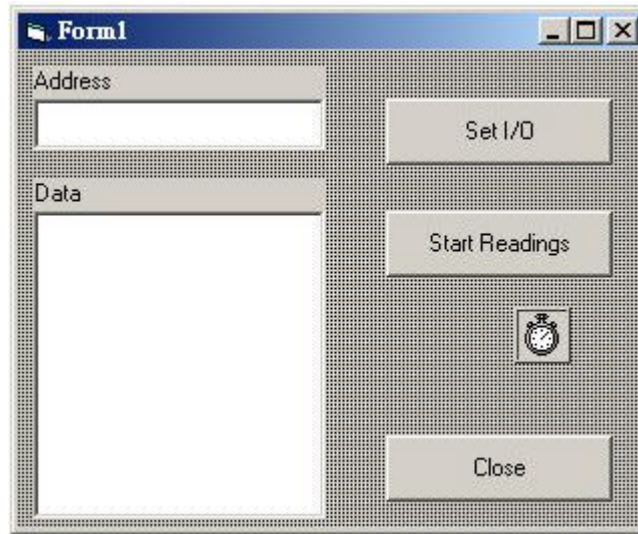

FIGURE C.1. The application will use a number of standard controls.

TABLE C.1. PROPERTY SETTINGS FOR THE CONTROLS ON THE APPLICATION DIALOG.

<i>Object</i>	<i>Property</i>	<i>Setting</i>
Command Button	Name	cmdSetIO
	Caption	Set I/O
Command Button	Name	cmdStartReading
	Caption	Start Readings
Command Button	Name	<i>cmdClose</i>
	Caption	Close
Label	Name	lblAddress
	Caption	Address
Label	Name	lblData
	Caption	Data
TextBox	Name	txtAddress
TextBox	Name	txtData

<i>Object</i>	<i>Property</i>	<i>Setting</i>
	MultiLine	True
Timer	Timer1	tmrPollForSRO
	<i>Interval</i>	<i>1000</i>
	Enabled	False

LISTING C.3. THE SRQFetch FUNCTION.

```

Dim M3500A As New IOUtils
Dim statusValue As Byte
Dim numberReadings As Long

Private Sub cmdClose_Click()      ' Command Button 1
    Unload Me
End Sub

Private Sub cmdSetIO_Click()      ' Command Button 2

    ' Set the io control address to the text box address
    ' we do this so the user can change address in text box
    ' and it will be reflected in the dialog
    txtAddress.Text = "GPIB0::22:INSTR"
    M3500A.Connect = txtAddress.Text

    ' Put the address from the communication dialog in text box
    txtAddress.Text = M3500A.Address
End Sub

Private Sub cmdStartReading_Click() ' Command Button 3
    ' Call the routine that sets up the meter

    cmdStartReading.Enabled = False

    startReadings

    cmdStartReading.Enabled = True
End Sub

Private Sub Form_Load()          ' Form1
    ' Load the forms address text box with persistent
    ' instrument address from INS001.IOUtils object
    txtAddress.Text = M3500A.Address
End Sub
Private Sub startReadings()

    Dim Average As Double
    Dim MinReading As Double
    Dim MaxReading As Double
    Dim Value As Integer
    Dim Mask As Integer
    Dim Task As Integer

    Continued on next page

```

```

On Error GoTo StartReadingsError

' Clear out text box for the data so we can see
' when new data arrives
txtData.Text = ""
txtData.Refresh

' *****
' Setup dmm to return an SRQ event when readings are complete
With M3500A
    ' Set the address from users text box
    .Output = "*RST"          ' Reset dmm
    .Output = "*CLS"          ' Clear dmm status registers
    .Output = "*ESE 1"        ' Enable 'operation complete bit to
                                ' set 'standard event' bit in status byte
    .Output = "*SRE 32"      ' Enable 'standard event' bit in status
                                ' byte to pull the IEEE-488 SRQ line
    .Output = "*OPC?"        ' Assure synchronization
    Value = .Input
End With

' *****
' Enable the SRQ polling so we can poll for SRQ
M3500A.EnableSRQ = True
txtData.Refresh

' *****
' Configure the meter to take readings
' and initiate the readings (source is set to immediate by default)
numberReadings = 10
With M3500A
    .Output = "Configure:Voltage:dc 10" ' set dmm to 10 volt dc range"
    .Output = "Voltage:DC:NPLC 10"      ' set integration time to 10 Power line cycles
(PLC)"
    .Output = "Trigger:count" & Str$(numberReadings) ' set dmm to accept multiple
triggers
    .Output = "Init"                    ' Place dmm in 'wait-for-trigger' state
    .Output = "*OPC"                    ' Set 'operation complete' bit in standard
' event registers when measurement is complete
End With

' *****

' enable the timer to poll gpib once per second
tmrPollForSRQ.Enabled = True

' give message that meter is initialized
' give message that configuration is done
txtData.Text = "Meter configured and " & vbCrLf & _
    "Initialized"

Exit Sub

StartReadingsError:
    Debug.Print "Start Readings Error = "; Err.Description
End Sub

Private Sub tmrPollForSRQ_Timer()'Timer1
    ' This timer when enabled will poll the GPIB
    ' and return the status byte to indicate if SRQ is set

    On Error GoTo pollerror

    Continued on next page

' this will also change the timeout
statusValue = M3500A.WaitOnSRQ(100)' WaitOnSRQ(100ms)

```



```

' Set the timeout back to 10 sec,
M3500A.Timeout = 10000
If statusValue = 64 Then ' SRQ from Operation complete
    ' Turn off the timer and stop polling.
    tmrPollForSRQ.Enabled = False
    Debug.Print "SRQ is set, getting data"
    ' Get the Data, the meter is ready
    ReadData
End If

Exit Sub

pollerror:
    Debug.Print "No SRQ yet, Poll error = "; Err.Description

End Sub

Private Sub ReadData()
    ' Once the SRQ is detected, this routine will
    ' get the data from the meter
    ' Called by: PollForSRQTimer_Timer
    ,
    Dim readings() As Double
    Dim i As Long

    On Error GoTo ReadDataError

    ' dimension the array for the number of readings

    With M3500A
        .Output = "Fetch?" ' Query for the data in memory
        readings = .Input ' get the data and parse into the array
    End With

    ' Insert data into text box
    txtData.Text = ""
    For i = 0 To UBound(readings)
        txtData SelText = readings(i) & " Vdc" & vbCrLf
    Next i

    Exit Sub

ReadDataError:
    Debug.Print "ReadData Error = "; Err.Description

End Sub

Private Sub Form_Terminate()

    On Error Resume Next

    Set M3500A = Nothing

End Sub

```

C++ DEVQUERY Sample Application

This C sample application is a Win32 console application. It illustrates how to use the INS001 IOUtils COM. A Win32 console application is a Win32 application which uses text-based input and output, not a

graphical interface. This allows you to quickly create a Win32 application by using simple input and output functions.

Creating the Application

Create a new Visual C++ project as follows:

1. Create a new Win32 Console Application project, calling the project DEVQUERY.
2. Specify that this project will be a simple application in the last AppWizard step.

LISTING C.4. THE DEVQUERY FUNCTION.

```
// devquery.cpp : Defines the entry point for the console application.
//

#include "stdafx.h"

//standard include for a Microsoft Visual C++ project
#include "stdio.h"
//need for COM
#include "windows.h"
#include "comdef.h"
//This is the 'Automation' object (COM class). It contains the
// IIOManger interface
//below
const CLSID CLSID_INS001IOUtils =
{0x0D955199,0x6CB9,0x441C,{0xBA,0xA7,0x4A,0xC4,0xB9,0x8C,0x3C,0x47}};

//The IIO allows the opening of a device using its address in the
// 'ConnectToInstrument' function. The IO class above exports this
// COM interface.

//The IIO function 'ConnectToInstrument' will return the IIO interface
//this is an instance of the instrument.
const IID IID_IOUtils=
{0xD3327DF2,0xB390,0x4888,{0x8D,0x89,0xB8,0x1D,0xBD,0x8A,0x9D,0x7F}};

//The following are the definitions needed to program the instrument.
//They can be placed in a header file for but are shown here to allow
// ease of perusal
/*****/
//This definition is to complete the IIO interface below. You needn't use
// this interface directly to communicate with instruments
extern "C" {
    interface IIIOUtils : IDispatch {
        STDMETHOD (Count)(short *pVal);
        STDMETHOD (TimeOut)(short *pVal);
        STDMETHOD (TimeOut)(short newVal);
        STDMETHOD (Open)(void);
        STDMETHOD (Close)(void);
        STDMETHOD (Refresh)(void);
        STDMETHOD (Index)(short newVal);
        STDMETHOD (Index)(short &newValue);
        STDMETHOD (Output)(BSTR newVal);
        STDMETHOD (Input)(BSTR *pVal);
        STDMETHOD (Address)(BSTR *pVal);
        STDMETHOD (Query)(BSTR newValue, BSTR *pVal);
    };
};
```

```

        STDMETHODCALLTYPE (Get_ErrFlag)(long *pVal);
        STDMETHODCALLTYPE (Connect)(BSTR newVal);
    };
} //extern "C"

int main(int argc, char* argv[])
{
    IIOUtils *IIO; //The IO we'll be using to get to the instrument
    HRESULT hr; //check return values for failure
    _variant_t myCmd;
    BSTR bstr;
    int dev_idx=0;
    short timeout=10000;
    short count;

    printf("\n ##### Start C++ Example program. #####\n");
    printf(" We check the M3500A multimeter on USB port and\n");
    printf(" identify the first connected M3500A device.\n\n");

    //Initialize COM
    CoInitialize(NULL);

    //Create the INS001 IOUtils component
    hr =
        CoCreateInstance(CLSID_INS001IOUtils, NULL, CLSCTX_INPROC_SERVER,
            IID_IOUtils, (LPVOID *)&IIO);
    if FAILED(hr)
    {
        printf("CoCreateInstance failed\n");
        return 0;
    }

    IIO->Refresh();
    IIO->Count(&count);
    if ( count == 0 )
    {
        printf("\n M3500A USB connect failed (USB).\n");
        return 0;
    }

    // Assigned the first M3500A device (USB port) for command test
    IIO->Index(dev_idx);
    IIO->TimeOut(&timeout);

    // Write command "*IDN?" and read the M3500A identification string
    myCmd = "*IDN?";
    IIO->Output(_bstr_t(myCmd));
    IIO->Input(&bstr);
    printf(" output : *IDN?\n");
    printf(" input : %s\n\n", (char *)_bstr_t(bstr));

    myCmd = "SAMP:COUN 1";
    IIO->Output(_bstr_t(myCmd));
    // Fetch the M3500A measure value ( screen value )

    // Set Voltage AC measure
    myCmd = "CONF:VOLT:AC 1,0.001";
    IIO->Output(_bstr_t(myCmd));
    myCmd = "READ?";
    IIO->Output(_bstr_t(myCmd));
    IIO->Input(&bstr);
    printf(" output : READ?\n");
    printf(" input : %s\n\n", (char *)_bstr_t(bstr));

    // Set Voltage DC measure
    myCmd = "CONF:VOLT:DC 10,0.1";
    IIO->Output(_bstr_t(myCmd));

```

```
myCmd = "READ?";
IIO->Output(_bstr_t(myCmd));
IIO->Input(&bstr);
printf("    output : READ?\n");
printf("    input  : %s\n\n", (char *)_bstr_t(bstr));

IIO->Close();
IIO->Release();
//Uninit so COM is exited clean.
CoUninitialize();

return 0;
}
```